

INSTRUCTION MANUAL
Automatic Ranging Digital Picoammeter
Model 445

COPYRIGHT 1974, KEITHLEY INSTRUMENTS, INC.
PRINTED JULY, 1978, CLEVELAND, OHIO U. S. A.
DOCUMENT NO. 29105

CONTENTS

<u>Section</u>	<u>Page</u>
SPECIFICATIONS -----	11
1. GENERAL DESCRIPTION -----	1
2. OPERATION -----	3
3. CIRCUIT DESCRIPTION -----	11
4. REPLACEABLE PARTS -----	29
5. CALIBRATION -----	51
SCHEMATICS -----	57

ILLUSTRATIONS

Fig. No.	Title	Page
1	Front Panel.	1
2	Front Panel Controls.	2
3	Rear Panel.	2
4	Triaxial Receptacle.	3
5	Reading Time.	4
6	Digital Display.	5
7	Printer/Control Connector.	9
8	Timing Diagram.	10
9	Feedback Ammeter.	11
10	Range Calibration.	11
11	Overall Block Diagram.	12
12	Autoranging Block Diagram.	13
13	A-to-D Converter Diagram.	14
14	Delay Hold Diagram.	15
15	Integrator Block Diagram.	15
16	Zero Crossing Detector.	15
17	Model 4401 Buffer Stage.	17
18	Chassis, Top View.	19
19	PC Board Locations.	20
20	Component Layout, PC-207.	21
21	Component Layout, PC-208.	21
22	Component Layout, PC-209.	22
23	Component Layout, PC-212.	22
24	Component Layout, PC-214.	23
25	Component Layout, PC-217.	23
26	Component Layout, PC-218.	24
27	Component Layout, PC-219.	24
28	Component Layout, PC-221.	25
29	Component Layout, PC-229.	27
30	Component Layout, PC-230.	27
31	Mechanical Assembly.	31
32	Test Equipment Set-up for A/D Calibration.	54
33	A/D Converter Zero Adjustments	55
34	Test Cover Template, Top Panel.	57
35	Test Cover Template, Bottom Panel.	58

SPECIFICATIONS

RANGE: 10^{-9} ampere full scale (10^{-12} ampere, least significant digit) to 10^{-2} ampere in eight decade ranges with 100% overranging on all ranges.

DISPLAY: Four digits from 000 to 1999; range exponent digit from 2 to 9; polarity, overload and Range Changing indication.

POLARITY SELECTION: Automatic.

RANGE SELECTION:

Automatic: Range change possible after each A to D conversion. An underrange condition (<100 digits) causes one range change to next more sensitive range. An overrange condition (>1999 digits) on any range causes range change to 10^{-2} A range.

Manual: Front panel switches permit manual range control.

ACCURACY AND RESPONSE TIME:

Range ampere	Calibrated Accuracy ¹ (% of reading)	Range Resistor		Analog Rise Time ² (10% - 90%)
		Stability	Temperature Coefficient	
10^{-2} to 10^{-4}	$\pm 0.2\% \pm 1$ digit	0.01%/yr	005%/°C	less than 1 ms
10^{-5}	$\pm 0.2\% \pm 1$ digit	0.5%/yr	015%/°C	4 ms
10^{-6}	$\pm 0.2\% \pm 1$ digit	0.5%/yr	015%/°C	5 ms
10^{-7}	$\pm 0.4\% \pm 1$ digit	1%/yr	05%/°C	8 ms
10^{-8}	$\pm 0.5\% \pm 1$ digit ³	2%/yr	05%/°C	20 ms
10^{-9}	$\pm 0.5\% \pm 1$ digit ³	3%/yr	2%/°C	40 ms

1. Calibrated at factory (23°C ambient). Internal adjustments on 10^{-9} to 10^{-2} ampere ranges for recalibration.

2. ± 2 digits with Filter out and 500 picofarads shunting the input.

3. With up to 500 picofarads shunting the input and Filter out.

FILTER: Improves ac rejection by lengthening rise time to approximately 3/4 s on 10^{-7} to 10^{-9} A ranges.

ZERO DRIFT: Less than 0.5% of full scale per week; less than 0.05%/°C, after 1/2-hour warm-up with source voltage greater than 2 volts.

DISPLAY RATE: 24 readings per second maximum (20 per second with 50-Hz units), adjustable to approximately 1 reading per two seconds.

With Filter in, maximum display rate is about 1/s.

INPUT VOLTAGE DROP: Less than 1 millivolt for full-scale display on all ranges when properly zeroed.

LINE FREQUENCY REJECTION: 60 dB (ratio of peak-to-peak current of power line frequency or multiple which will cause less than 1 digit of error, to that error). 100 dB on 10^{-9} to 10^{-7} A ranges with Filter in. Peak input current should not exceed 20 mA.

MAXIMUM INPUT OVERLOAD: 1000 volts using a Keithley or other current limited (up to 20 milliamperes) High Voltage Supply with Model 445 in autorange mode. Instantaneous input current must never exceed 125 milliamperes.

ANALOG OUTPUT: ± 1 volt from a 500-ohm source for full-scale display. Maximum output, 1 milliampere. Output polarity is opposite input polarity.

PRINTER OUTPUTS AND REMOTE CONTROLS:

Printer Outputs: BCD positive output represents each of the four digits, range, polarity, overrange, range changing and zero check. Standard code is 1-2-4-8. "0" <+0.4 volt; "1" >+10 volts at up to one milliampere; 0=0000.

Print Command A: Positive pulse of 14 volts from a 2200-ohm source with 1 volt per microsecond rise time. 100 microseconds minimum pulse width. Print command given after each A to D conversion.

Print Command B: Same as Print Command A except present only when displaying an onrange reading.

Remote Controls:

Hold # 1: Closure* to ground inhibits A to D conversion at that instant.

Hold # 2: Closure* to ground inhibits A to D conversion after reading has been completed.

Trigger: Closure* to ground initiates one conversion when in Hold # 2. Integration period starts 8.3 milliseconds (10 milliseconds on 50-Hz models) after "Trigger" or release of Hold # 2.

Range Hold: Closure* to ground prevents range change.

Zero Check: Closure* to ground places instrument in zero check mode and prevents range change.

10^{-2} Range: Closure* to ground places instrument in 10^{-2} ampere range and holds until 10^{-2} Range released.

ISOLATION: Circuit ground to chassis ground: Greater than 10^6 ohms shunted by .02 microfarad. Circuit ground may be floated up to 100 volts with respect to chassis ground.

COMMON MODE REJECTION: 100 V dc or 200 V peak-to-peak at line frequency will not affect reading.

CONNECTORS: Input: Teflon-insulated triaxial. Analog output: Amphenol 80-PC2F. Printer outputs and remote controls: 50-pin Amphenol Micro-Ribbon. Low and case ground: Binding posts.

POWER: 105-125 or 210-250 volts (switch selected), 60 Hz. 50-Hz models available. 30 watts.

DIMENSIONS, WEIGHT: 5 1/4" high x 19" wide by 10" deep; net weight, 15 pounds.

ACCESSORIES SUPPLIED:

Model 4451 Input Cable: 48" triaxial cable with triaxial connector and 3 alligator clips.

Mating digital output connector.

*or saturated NPN transistor.

SECTION 1. GENERAL DESCRIPTION

1-1. GENERAL. The Model 445 is a sensitive Automatic Ranging Digital Picoammeter with eight ranges from 10^{-9} to 10^{-2} ampere plus 100% overranging.

1-2. FEATURES.

a. Stability. Zero drift with time is less than 1 digit per day; drift with temperature is less than one digit per °C, making frequent adjustment unnecessary.

b. Overload Protection. A transient overload of 1000 volts at up to 20 mA will not damage the instrument.

c. Damping. A front panel FILTER Switch selects additional damping of noisy signals on the 10^{-7} , 10^{-8} , and 10^{-9} ampere ranges.

d. Digital Display. The digital display provides 3 digits with 10^{-12} ampere resolution.

e. Variable Display Rate. A front panel DISPLAY RATE control adjusts from 24 readings/sec. to 1 reading/2 sec. to accommodate the mode of data retrieval.

f. Autoranging. Autorange circuit senses the input current and automatically selects the proper range for each measurement.

g. Complete BCD Output and Control Lines. Binary-Coded-Decimal Outputs are provided on a rear panel connector for significant digits, range, polarity, overrange, and zero check. Control lines are also provided for remote control of ranging and A/D conversions.

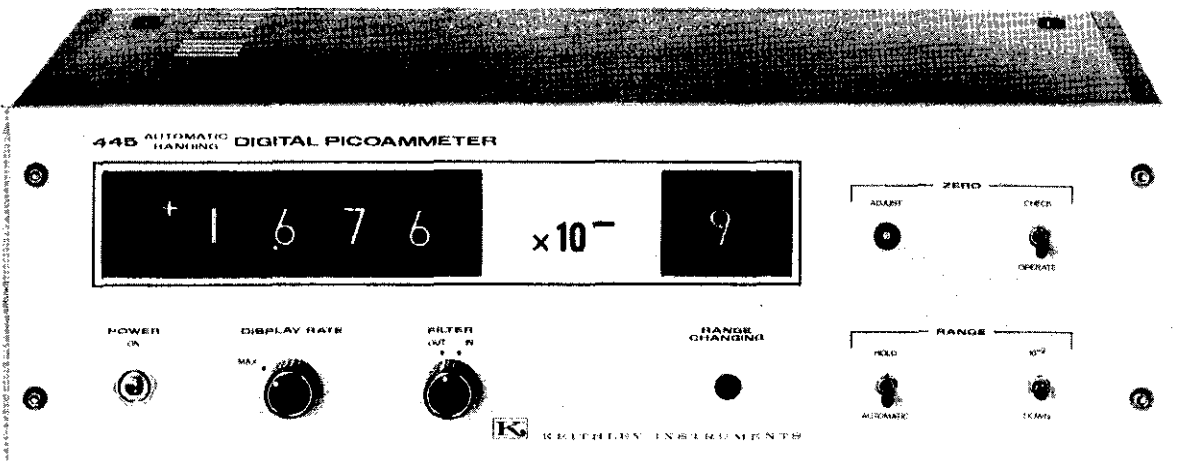

TABLE 1-1.
Front Panel Controls.

Control	Functional Description	Paragraph
POWER Switch (S102)	Controls power to instrument.	2-3, a
ZERO CHECK (S1204)	Selects Zero Check Mode.	2-3, b
ZERO ADJUST (R1207)	Adjusts the zero offset.	2-3, c
FILTER Switch (S1201)	Selects additional filtering.	2-3, d
RANGE-HOLD/AUTOMATIC (S1203)	Selects HOLD or AUTOMATIC modes.	2-3, e
RANGE - 10^{-2} /DOWN (S1202)	Permits manual range selection.	2-3, f
DISPLAY RATE (R1237)	Adjusts the A/D conversion rate.	2-3, g

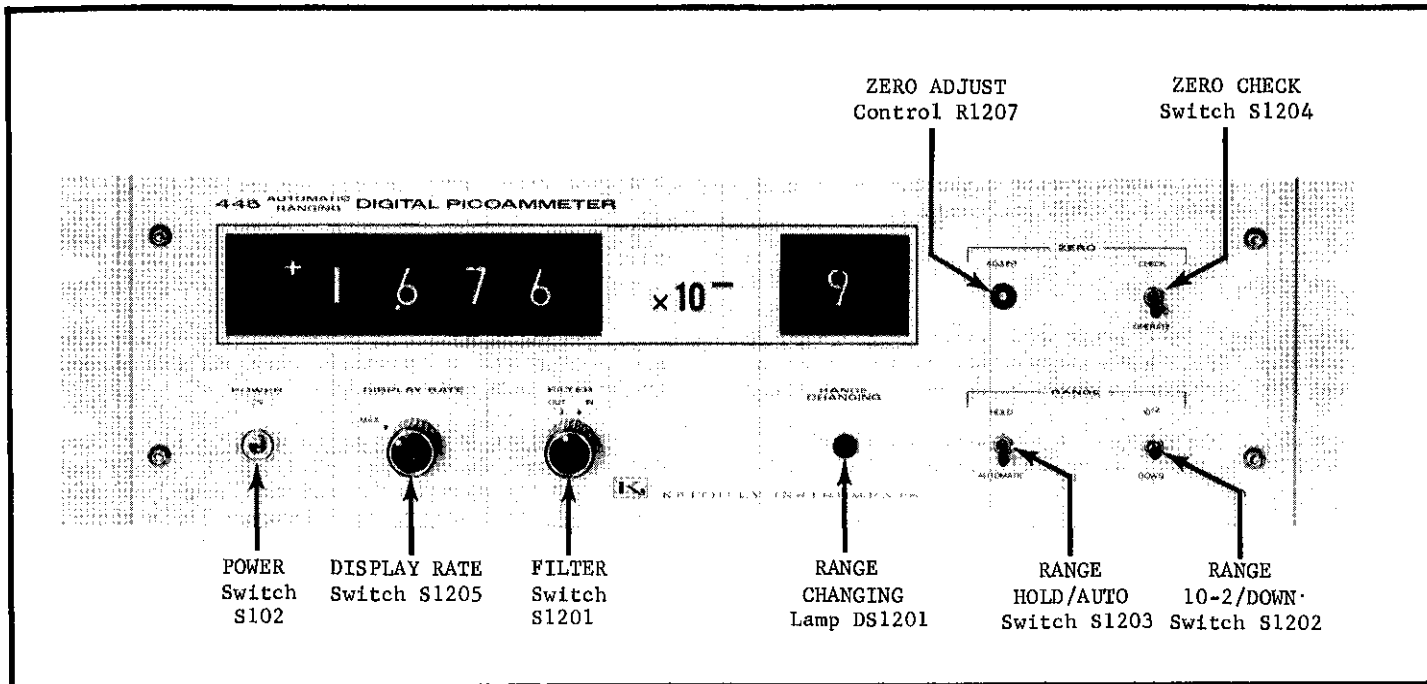

FIGURE 2. Front Panel Controls.

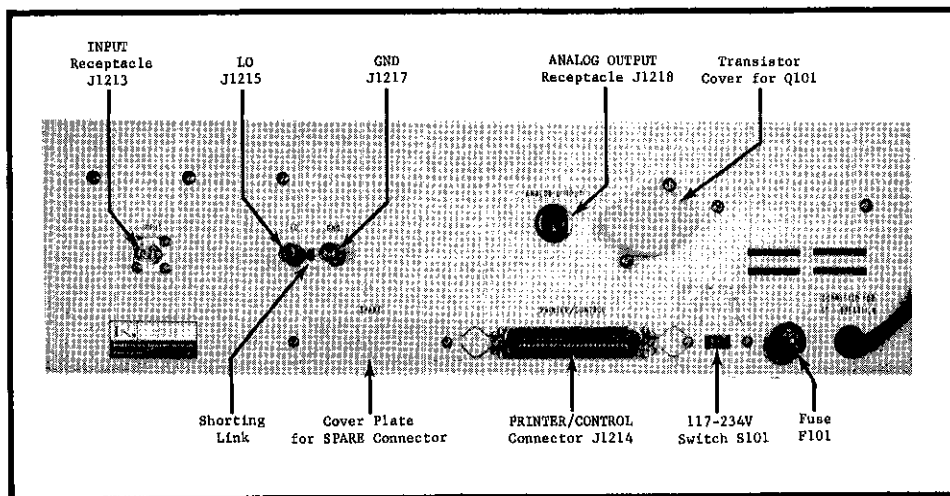

FIGURE 3. Rear Panel.

TABLE 1-2.
Rear Panel Terminals.

Terminal	Functional Description	Paragraph
INPUT Receptacle (J1213)	Input connector, triaxial type.	2-1, a
LO Binding Post (J1215)	Input LO connector.	2-1, a
GND Binding Post (J1217)	Chassis Ground connector	2-1, a
PRINTER/CONTROL Connector (J1214)	Provides BCD outputs and control lines; 50 pins.	2-8, a
ANALOG OUTPUT (J1218)	Analog Output connector, Mates with Keithley Part No. CS-33.	2-7

SECTION 2. OPERATION

2-1. INPUT CONNECTIONS.

a. Input Receptacle. The input connector (J1213) on the rear panel is a Teflon-insulated triaxial type (Keithley Part No. CS-181). The center terminal is the High Impedance terminal; the inner shield is the Low Impedance terminal; and the outer shield is Case Ground as shown in Figure 4. The rear panel LO terminal is connected to the Low Impedance terminal. When the "shorting link" on the rear panel is connected between LO and GND, the Low Impedance Terminal is then at chassis ground for non-floating applications. The rear panel "GND" terminal (J1217) can be used for connections to system ground.

b. Input Cables. Input connections should be made using triaxial cables which are low-noise types with graphite coating between dielectric and shield braid. For custom length cables, Keithley Part No. SC-22 Low-Noise Triaxial Cable should be used.

1. Model 4451 Input Cable (Supplied). This cable is a pre-assembled cable, 48-inches long having a triaxial male connector on one end and 3 color-coded alligator clips on the other.

2. Model 6012 Adapter. This adapter can be used with coaxial cables and connectors when a triaxial cable is not required. The adapter provides a UHF female-to-triax male connection.

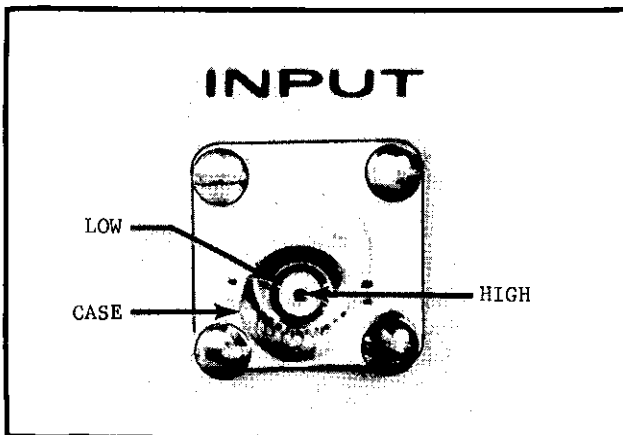

FIGURE 4. Triaxial Receptacle.

2-2. MEASUREMENT CONSIDERATIONS.

a. Noise. The limit of resolution in voltage and current measurements is determined largely by the noise generated in the source. Stray low-level noise is present in some form in nearly all electrical circuits. The instrument does not distinguish between stray and signal currents since it measures the net current. When using the picoampere ranges, consider the presence of low-level electrical phenomena such as thermocouples (thermoelectric effect), flexing of coaxial cables (triboelectric effect), apparent residual charges on capacitors (dielectric absorption), and battery action of two terminals (galvanic action).

1. Thermal EMFS. Thermoelectric potentials (thermal emfs) are generated by thermal gradients between two junctions of dissimilar metals. These can often be large compared to the signal to be measured. To minimize the drift caused by thermal emfs, use pure copper leads wherever possible in the source circuit. Drift can also be minimized by maintaining constant junction temperatures especially by using a large heat sink near the connections. The Keithley accessory Model 1483 Low Thermal Connection Kit contains all necessary materials for making very low thermal copper crimp connections for minimizing thermal effects.

2. AC Electric Fields. The presence of electric fields generated by power lines or other sources can have an effect on instrument operation. AC voltages which are very large with respect to the full-scale range sensitivity could drive the ac amplifier into saturation, thus producing an erroneous dc output. Proper shielding as described in paragraph 2-1, d can minimize noise pick-up when the instrument is in the presence of large ac fields or when very sensitive measurements are being made.

3. Magnetic Fields. The presence of strong magnetic fields can be a potential source of ac noise. Magnetic flux lines which cut a conductor can produce large ac noise especially at power line frequencies. The voltage induced due to magnetic flux is proportional to the area enclosed by the circuit as well as the rate of change of magnetic flux. For example, the motion of a 3-inch diameter loop in the earth's magnetic field will induce a signal of several tenths of a microvolt. One way to minimize magnetic pickup is to arrange all wiring so that the loop area enclosed is as small as possible (such as twisting input leads). A second way to minimize magnetic pickup is to use shielding as described in paragraph 2-1, b.

b. Shielding.

1. Electric Fields. Shielding is usually necessary when the instrument is in the presence of very large ac fields or when very sensitive measurements are being made. The shields of the measurement circuit and leads should be connected together to ground at only one point. This provides a "tree" configuration, which minimizes ground loops.

2. Magnetic Fields. Magnetic shielding is useful where very large magnetic fields are present. Shielding, which is available in the form of plates, foil or cables, can be used to shield the measuring circuit, the lead wires, or the instrument itself.

c. Damping. The amount of high frequency noise which will be observed on the picoammeter is determined by: 1) The noise pickup at the input, and 2) The bandwidth of the amplifier circuit. The front panel FILTER Switch (S1201) sets the amount of filtering from a minimum (as stated in the rise time specification) to a maximum value when placed to "IN" position. The rise time is increased to approximately 3/4 second on 10^{-7} to 10^{-9} ampere ranges.

d. Accuracy. The accuracy is specified in terms of a percent of reading on each range. An additional ± 1 digit is specified since the A/D conversion has an inherent ± 1 digit uncertainty. Noise and source resistance conditions should be evaluated as additional measurement considerations.

e. Source Resistance. The value of source resistance can affect the measurement if the loading effect of the picoammeter is significant. To avoid a degradation of zero drift, the picoammeter range should be selected so that the range feedback resistor is much less than the source resistance. The zero drift specification is valid only for source voltages greater than 2 volts.

f. Overloads. A unique input circuit provides complete overload protection with fast recovery. The maximum overload is 1000 volts using a current limited supply (up to 20mA) such as Keithley Models 240A, 245, or 246. Instantaneous input current must never exceed 125 milliamperes. With an input voltage up to 1000 volts use a current limited supply or a series limiting resistor (8000 ohms minimum).

g. Reading Time. The time interval for a new reading to take place depends on the Model 445 front panel settings as well as the characteristics of the input signal. The various time intervals which constitute the total reading time are described as follows. The intervals are graphically shown in Figure 5.

1. T_1 = A/D Conversion Time until first range change.
2. T_2 = Total Time for all successive range changes.
3. T_3 = A/D Conversion Time to first on-scale reading.
4. T_4 = Total Settling Time until reading is final.

h. Off-Ground Measurements. The Model 445 can be used for off-ground measurements with the circuit low floated up to 100 volts with respect to chassis ground. Circuit low to chassis ground isolation is greater than 10^6 ohms shunted by .02 microfarad. When making off-ground measurements disconnect the LO to GND shorting link on the rear panel. A triaxial cable should be used to maintain noise shielding and to provide user safety. The BCD outputs are connected to circuit low and therefore must be used with devices which can be operated off-ground.

TABLE 2-1.
Typical Reading Time With Filter "OUT".

Input Signal	Initial Range	Sampling Time T_1 Sec.	Range Changes	Ranging Time T_2 Sec.	Final Range Time T_3 Sec.	Settling Time T_4 Sec.	Total Time Sec.
10 ⁻⁹ A	10 ⁻² A	.042 (1)	7	.294 (7)	.042 (1)	.120 (3)	.498 (12)
10 ⁻⁸ A	10 ⁻² A	.042 (1)	6	.252 (6)	.042 (1)	.060 (3)	.396 (11)
10 ⁻⁷ A	10 ⁻² A	.042 (1)	5	.210 (5)	.042 (1)	.018 (3)	.312 (10)
10 ⁻⁶ A	10 ⁻² A	.042 (1)	4	.168 (4)	.042 (1)	.015 -	.267 (6)
10 ⁻⁵ A	10 ⁻² A	.042 (1)	3	.126 (3)	.042 (1)	.012 -	.222 (5)
10 ⁻⁴ A	10 ⁻² A	.042 (1)	2	.084 (2)	.042 (1)	.003 -	.171 (4)
10 ⁻³ A	10 ⁻² A	.042 (1)	1	.042 (1)	.042 (1)	.003 -	.129 (3)
10 ⁻² A	10 ⁻² A	.042 (1)	0	0 (0)	.042 (1)	.003 -	.087 (2)

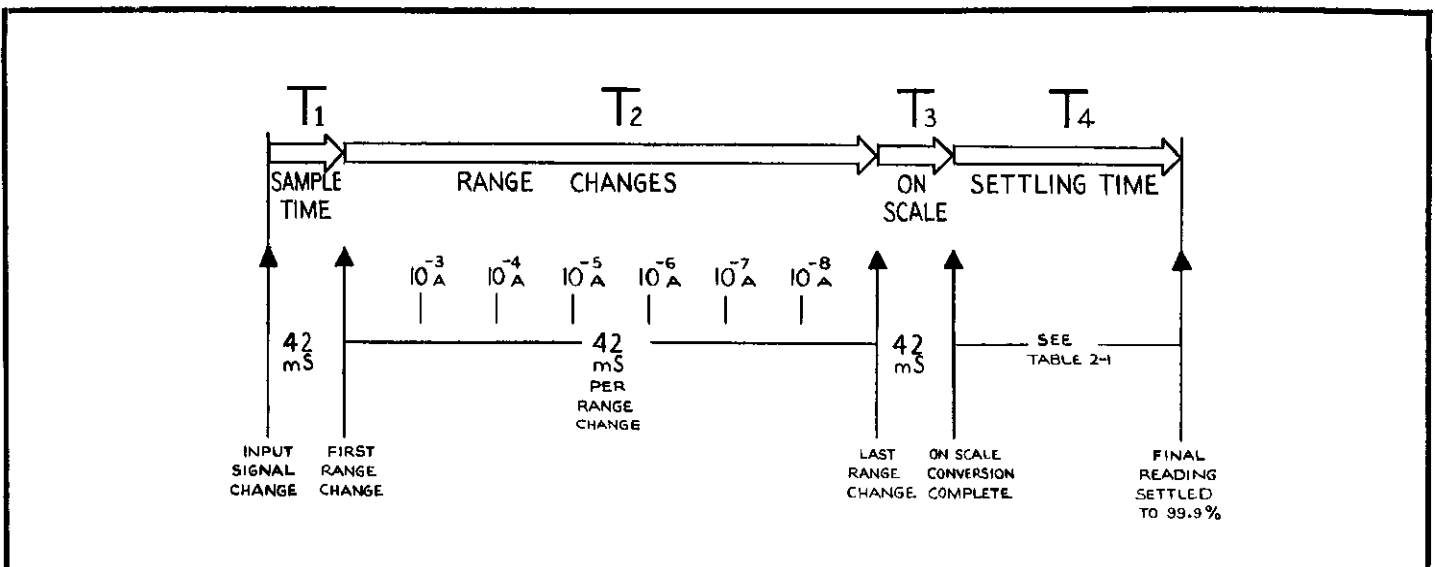

FIGURE 5. Reading Time.

2-3. FRONT PANEL CONTROLS.

a. POWER Switch (S102). This switch controls the line power to the instrument. A rear panel fuse F101 protects the instrument in case of malfunction of the power supply or power switch.

b. ZERO CHECK Switch (S1204). This switch selects either "NORMAL" or "ZERO CHECK" modes of operation. In "ZERO CHECK" position, a relay is activated which places a short across the feedback of the picoammeter. Zero Controls R1238 and R1207 can be used to adjust the zero offset as necessary.

c. ZERO ADJUST (R1207). This control provides "FINE" adjustment of the zero offset. The internal zero control R1238 provides "COARSE" adjustment.

d. FILTER Switch (S1201). This switch selects either minimum damping ("OUT" position) or additional damping ("IN" position). A more complete discussion of the "FILTER" mode is given in paragraphs 2-2, c and 2-2, g.

e. RANGE - HOLD/AUTOMATIC Switch (S1203). This switch selects automatic ranging operation in "AUTOMATIC" position or manual ranging in "HOLD" position. In "HOLD", the range is held at the existing range displayed until the switch is changed or the range is manually changed by either S1202 or the external control lines.

f. RANGE - 10^{-2} /DOWN Switch (S1202). This switch is a momentary-contact, normally open switch for manual range changes. This switch should be used with Switch S1203 in the HOLD position. When Switch S1202 is momentarily set to " 10^{-2} ", the Picoammeter resets the range display to 10^{-2} . However, each time the switch is set to "DOWN" position, the picoammeter down ranges to a more sensitive range. The sequence of down ranging would be typically 10^{-2} , 10^{-3} , 10^{-4} , 10^{-5} , etc. (with a reset after 10^{-9} range is reached, that is 10^{-8} , 10^{-9} , 10^{-2}).

g. DISPLAY RATE (R1237). This control adjusts the A/D Converter conversion rate from 24 readings/sec. (MAX) to 1 reading/2 sec. (approx).

2-4. OPERATING PROCEDURE.

a. Preliminary Procedure.

1. Check the 117-234V Switch (S101) on the rear panel for proper line voltage.
2. Check for proper rated fuse.
3. Connect the power cord, place the POWER Switch ON, and allow a 30-minute warmup for critical measurements.
4. Adjust the ZERO Control (R1207) as necessary. Zero is indicated by alternately flashing + polarity lights.
5. Connect the source as described in paragraph 2-1.

b. Measurements. The Model 445 measures current over a full-range from 10 milliamperes (10^{-2} A) to 1 nanoampere (10^{-9} A) with resolution to 1 picoampere (10^{-12} A). The display will indicate either a positive or negative input current automatically. (A positive current is defined as a positive "conventional current" applied at Input High with respect to Input Low).

2-5. DIGITAL DISPLAY. The display has three digits plus one for overrange indication. The range is displayed in scientific notation where the exponent is automatically displayed for ranges 10^{-2} through 10^{-9} amperes. To interpret the display refer to Figure 6. An overload condition will cause the display tubes to blank out so that no ambiguous display is possible. This situation is described under 2-4, d Autoranging.

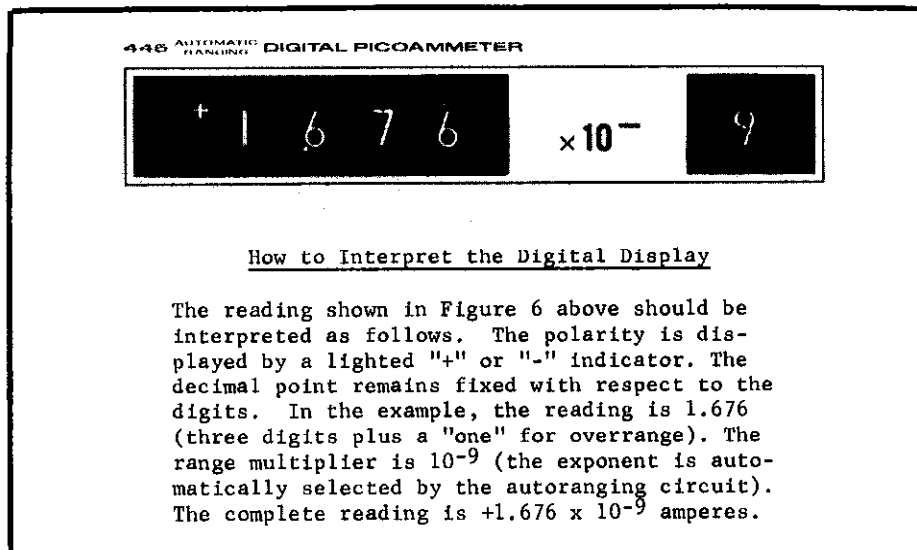

FIGURE 6. Digital Display.

TABLE 2-2.
Output Information and Controls.

Model 4401 Printer Output Cards: Provide BCD output and external control of Model 445; may be purchased installed or separately for field installation (no wiring required).

Printer Outputs: BCD positive output represents each of the four digits, exponent, range, zero, polarity and overrange. Standard code is 1-2-4-8. "0" \leq +0.4 volt; "1" $>$ +10 volts at up to one milli-ampere; 0=0000.

Print Command: Positive pulse of 14 volts from a 2200-ohm source with 1 volt per microsecond rise time, 100 microseconds minimum pulse width.

Remote Controls:

Hold #1: Closure to ground inhibits A to D conversion at that instant.

Hold #2: Closure to ground inhibits A to D conversion after reading has been completed.

Trigger: Closure to ground initiates one conversion when in Hold #2. Integration period starts 8.3 ms (10 ms on 50-Hz models) after "Trigger" or release of Hold #2.

Connector: 50-pin Amphenol Micro-Ribbon mounted on Model 445. Output mating connector supplied with 4401.

NOTE

The term "Closure to Ground" or "Grounded control line" means a short to common directly or through a saturated NPN transistor ($V_{CE} \leq +0.4V$). Only the "COMMON" as supplied at the PRINTER/CONTROL connector should be used for closures to ground.

TABLE 2-3.
Full Scale Magnitude.

Connector Pin No.	Output	Decimal Digits
1	1×10^0	1
2	2×10^0	2
26	4×10^0	4
27	8×10^0	8
3	1×10^1	1
4	2×10^1	2
28	4×10^1	4
29	8×10^1	8
5	1×10^2	1
6	2×10^2	2
30	4×10^2	4
31	8×10^2	8

2-6. **AUTORANGING.** The automatic ranging feature of the Model 445 permits rapid measurements of a wide range of currents.

a. AUTOMATIC Mode. In this mode the Model 445 will automatically select the full-range that permits a display from 0.100 to 1.999. The Model 445 changes range in decade steps from a less sensitive range to a more sensitive range. This process is defined as "down-ranging". If the input current causes the display to exceed 1.999, then the Model 445 will automatically change to "10⁻²" range and "down-range" until the display is between 0.100 and 1.999.

1. **DOWN Range Control.** The use of Switch S1202 permits manual range changing. This switch is a momentary-contact type switch. Each time the switch is depressed to "DOWN" position, the range will "down-range" from a less sensitive range to a more sensitive range. When the 10⁻⁹ range is reached, actuation of the switch will cause the range to go to 10⁻² or "reset" position.

2. **10⁻² Range Control.** When switch S1202 is set to "10⁻²" position, the range will be "reset" to the 10⁻² range regardless of the current input. Once the switch is released the Model 445 will revert to normal operation.

b. HOLD Mode. When switch S1203 is set to "HOLD" position, the full range of the instrument will hold regardless of the input current. This switch position inhibits the operation of the DOWN/10⁻² switch.

NOTE

If the input current exceeds 1.999 for the range in "HOLD", the display tubes will blank indicating an overload on that range. If Switch S1203 is set to "AUTOMATIC" the Model 445 will change to 10⁻². Then if the input current does not exceed 1.999 on the 10⁻² range, the display will indicate normally when the final range is selected.

2-7. **ANALOG OUTPUT.** The analog output on the rear panel (J1218) provides a voltage of 1.05 volts corresponding to 1.000 on any range. Since this output has a source resistance of 499 ohms, the recording device must have a load resistance greater than 10 kilohms to obtain 1.000 volt for full range. If a recorder such as the Keithley Model 370 is available, an Isolation Amplifier (such as Keithley Model 399) must be used to provide up to 1 milliamper current for full range.

2-8. DIGITAL OUTPUT.

a. General. The Model 445 has output buffer printed circuit boards which provide Binary Coded Decimal (BCD) outputs. A factory wired 50-pin PRINTER/CONTROL connector is provided on the rear panel (J1214). A spare cutout is provided on the rear panel for installation of an additional PRINTER/CONTROL connector.

b. Output Codes and Levels. The PRINTER/CONTROL Outputs are Binary Coded Decimal signals with 1-2-4-8 Standard Code. The Standard signal levels are as follows:

Logic "0" < +0.4 volt
Logic "1" > +10 volts at up to 1 milliampere.

c. Output Information. The various Output Information and Controls are summarized in Table 2-2.

1. **Full Scale Magnitude.** The Magnitude of the reading is indicated by BCD outputs which correspond to the three front panel display lights (three significant digits) as shown in Table 2-3.

2. **Overrange Indication.** Overrange is indicated by the fourth (from the right) display light and corresponding BCD output as shown in Table 2-4. Overload is indicated by a blanked display and corresponding BCD output. The output at pin 33 will be a logic "1" while the magnitude will be represented by logic "0" as shown in Table 2-4.

TABLE 2-4.
Overrange and Overload Outputs

Connector Pin No.	Output	Decimal Digits
7	1 x 10 ³	1
8	Common	0
32	Common	0
33	Overload (8 x 10 ³)	8

3. **Polarity and Zero Check Indication.** The polarity is indicated automatically by the Polarity indicator and corresponding BCD output as shown in Table 2-5. Additional BCD levels are available at pins 14 and 39 for use with some printers. The zero check mode is indicated by a BCD output from pin 38.

TABLE 2-5.
Polarity Output

Connector Pin No.	Output	Decimal Digits
13	Polarity	1
14	+ 15V	2
38	Zero Check	4
39	+ 15V	8

4. **Range Indication (Exponent).** The range or exponent has a corresponding BCD output as shown in Table 2-6.

TABLE 2-6.
Range or Exponent Indication

Connector Pin No.	Output	Decimal Digits
9	1 x 10 Range	1
10	2 x 10 Range	2
34	4 x 10 Range	4
35	8 x 10 Range	8

5. Ranging Signal. A single binary signal is available at pin 49 which corresponds to a ranging signal. The logic level is "1" whenever range changes are occurring so as to indicate invalid readings.

d. External Control.

1. General. To obtain optimum system performance, it is often desirable to operate the Model 445 synchronously with other digital equipment such as printers, paper tape punches, computers, and other data handling devices.

2. Applications. Several approaches may be used in designing the overall system control scheme.

a). The Model 445 can be used to provide master control of external devices so that maximum possible conversion rates can be obtained.

b). An external device can be used for master control, such as a high speed printer.

c). A completely independent "master clock" can be used for system control for maximum flexibility.

3. Description.

a). "HOLD 1". This control inhibits A to D conversion at the instant a closure to ground is made. The conversion cycle will resume immediately when the "HOLD 1" line is opened.

b). "HOLD 2". This control inhibits A to D conversion after a complete reading cycle. Further conversions are inhibited as long as a closure to ground is made. The conversion cycle will resume immediately when the "HOLD 2" line is opened.

c). "TRIGGER". This control initiates one complete conversion when "HOLD 2" line is grounded. Closure to ground may be momentary or any longer duration to initiate a conversion.

d). "PRINT COMMAND A". This control provides a positive going pulse of 14 volts after a complete A to D conversion is made and all data outputs are final readings. No change can take place (except Zero Check) for 25 milliseconds. This "Print Command" signal is present regardless of the mode (AUTOMATIC or HOLD).

e). "PRINT COMMAND B". This control is similar to "Print Command A" except that no signal is present if the instrument is changing range.

f). Zero Check. This control places the Model 445 in Zero Check and prevents automatic range change when a closure to ground is made.

g). Range Hold Control. This control prevents automatic range change when a closure to ground is made.

h). 10^{-2} Range Hold Control. This control causes the range to change to 10^{-2} when a closure to ground is made. The range is held until the line is released.

i). High and Low References. Two reference voltages are provided to define the "HIGH" and "LOW" digital output states for external printers or other devices; "HIGH" = +8V; "LOW" = +2V.

e. Summary of Digital Outputs and Controls.

1. Standard Output Codes and Levels. The standard output code for Model 4401 Printer Output Cards is 1-2-4-8 Binary Coded Decimal (BCD). A binary coded decimal digit is represented by a four-bit binary code as shown in Table 2-7.

TABLE 2-7.

Decimal Number	4 bit	3 bit	2 bit	1 bit
0	0	0	0	0
1	0	0	0	1
2	0	0	1	0
3	0	0	1	1
4	0	1	0	0
5	0	1	0	1
6	0	1	1	0
7	0	1	1	1
8	1	0	0	0
9	1	0	0	1

Refer to Figure 17 for a circuit diagram of the Model 4401 Standard Printer Output buffer stage.

TABLE 2-8.
Typical Digital Outputs.

Front Panel Digital Display	Range Exponent	Sign, Digit Polarity	Digit or Overload	Mag.	Range Exp.	Ranging Signal	Interpretation
+ 0.275	10^{-5}	+	0	275	5	0	+ .275 x 10^{-5} A
+ 1.347	10^{-9}	+	1	347	9	0	+ 1.347 x 10^{-9} A
- (blank)	10^{-2}	-	8	000	2	0	negative overload
+ (blank)	10^{-7}	+	8	000	7	0	positive overload
- 0.023	10^{-3}	-	0	023	3	0	- .023 x 10^{-3} A
+ 1.962	10^{-6}	+	1	962	6	1	ranging
- 0.586	10^{-4}	-	0	586	4	1	ranging

TABLE 2-9.
 PRINTER/CONTROL Connector Pin Identification.

Pin No.	Output	Function	Pin No.	Output	Function
1	1×10^0	Data	26	4×10^0	Data
2	2×10^0	Data	27	8×10^0	Data
3	1×10^1	Data	28	4×10^1	Data
4	2×10^1	Data	29	8×10^1	Data
5	1×10^2	Data	30	4×10^2	Data
6	2×10^2	Data	31	8×10^2	Data
7	1×10^3	Data	32	Common	---
8	Common	---	33	8×10^3	Overload
9	1×10^0	Range	34	4×10^0	Range
10	2×10^0	Range	35	8×10^0	Range
11	Blank	---	36	Common	---
12	Common	---	37	Common	---
13	1×10^0	Polarity	38	1×10^0	Zero Check
14	+ 15V	---	39	+ 15V	---
15	Blank	---	40	Blank	---
16	Blank	---	41	Blank	---
17	+ 15V	---	42	- 15V	---
18	+ 3.6V	---	43	Common	---
19	Grounded	Remote Zero Check	44	Grounded	Hold # 1
20	Grounded	Remote 10^{-2}	45	Grounded	Hold # 2
21	Grounded	Remote Range Hold	46	Grounded	Trigger
22	Blank	---	47	Blank	---
23	+ 14V Pulse	Print Command A	48	+ 14V Pulse	Print Command B
24	+ 8V	Hi Reference	49	1×10^0	Ranging Signal
25	+ 2V	Low Reference	50	Blank	---

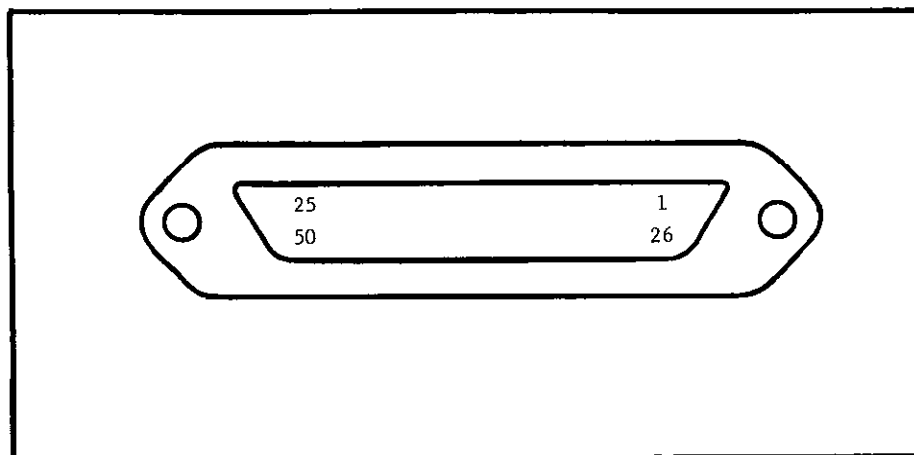

FIGURE 7. Printer/Control Connector.

2. **PRINTER/CONTROL Connector.** The PRINTER/CONTROL Connector used on the Model 445 provides for connections to 50 pins as shown in Table 2-9. The mating connector supplied is an Amphenol Part No. 57-30500 or Keithley Part Number CS-220.

3. **Analog-to-Digital Conversion Cycle.**

a). The analog-to-digital conversion cycle can be initiated in any one of three ways.

1. **DISPLAY RATE Control Set at MAX.** With the DISPLAY RATE Control set at MAX, the end of one complete conversion triggers a second conversion to obtain the maximum conversion rate of 24 readings per second.

2. **DISPLAY RATE Control Set at Other Than MAX.** With the DISPLAY RATE Control set at some position other than MAX, (uncalibrated control setting) the end of one complete conversion triggers a second conversion which is delayed by a specific time interval (DELAY). The time delay is a function of the position of a continuously variable control to provide a conversion rate from 24 readings per second to 2 readings per minute.

3. **"HOLD 2" With TRIGGER Control.** With the "HOLD 2" command grounded, a closure to ground of the "TRIGGER" command initiates one complete conversion cycle. A second conversion will follow only if the TRIGGER command is removed and reapplied a second time. The maximum conversion rate using an external trigger is 24 readings per second.

b). **Conversion Cycle Timing.** The Conversion Cycle is composed of three timing periods, namely Integrator Zero, Integrator Sampling, and AD Counting period. Refer to Timing Diagram Figure

1. **Integrator Zero Period (ZERO).** When a trigger pulse initiates a new conversion cycle, the Integrator circuit is zeroed for a period not to exceed 8.33 milliseconds for 60 Hz operation. (The Integrator Zero Period is 10.00 milliseconds for 50 Hz operation).

2. **Integrator Sampling Period (INTEGRATE).** The Integrator Sampling Period follows automatically the Integrator Zero Period and lasts for the duration of 16.67 milliseconds for 60 Hz operation. The Integrator Sampling Period lasts for a duration of 20.00 milliseconds for 50 Hz operation.

3. **AD Counting Period (COUNT).** The AD Counting Period is initiated immediately following the Integrator Sampling Period. The actual counting time duration will depend on the actual integrator voltage up to a maximum of 2000 clock pulses of 16.67 milliseconds. Following the counting period a Buffer/Storage command is automatically generated in order to store the new reading in the output registers.

2-9. **117-234V LINE POWER OPERATION.** The Model 445 is shipped for use with 117V ac line power unless ordered for 234V operation. To convert any instrument for either 117V or 234V operation, use a screwdriver to set the 117-234V Switch on the rear panel. The

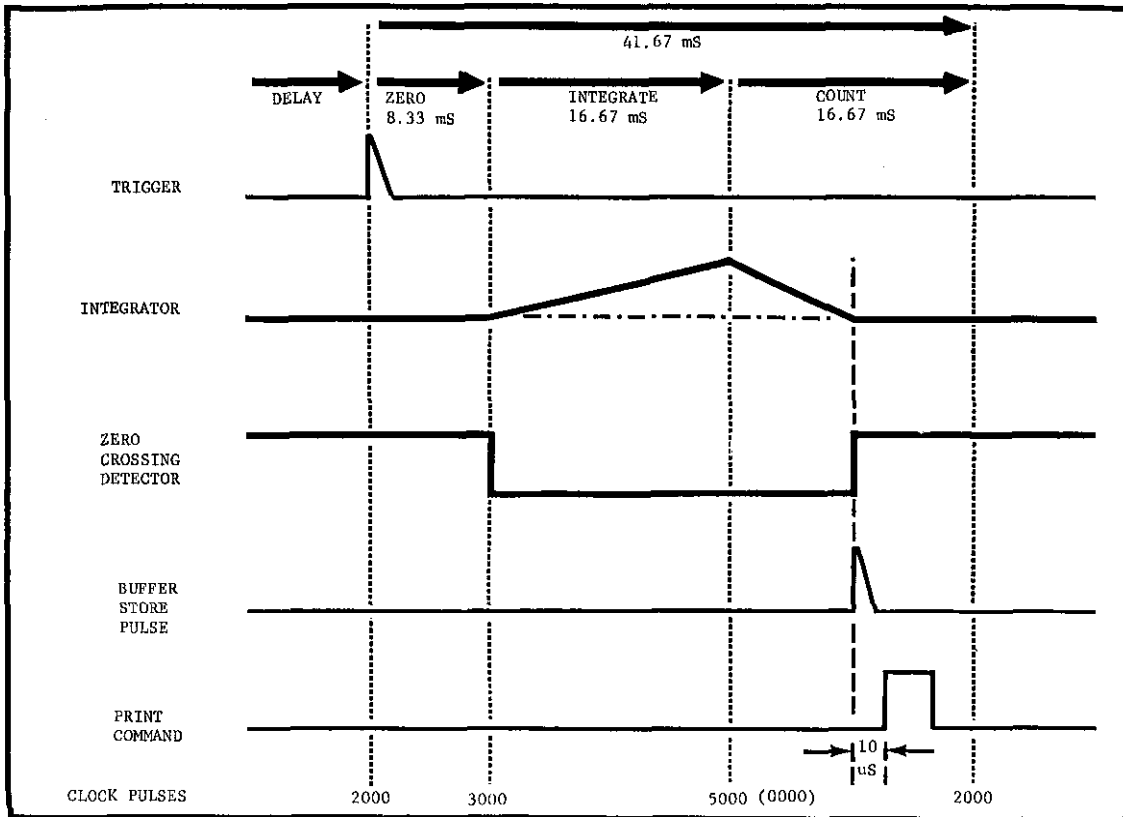

FIGURE 8. Timing Diagram.

SECTION 3. CIRCUIT DESCRIPTION

3-1. GENERAL. The Model 445 consists of three sections packaged together in one chassis: a sensitive picoammeter, an automatic ranging circuit, and an analog-to-digital converter.

a. Picoammeter. The picoammeter is a linear dc amplifier connected as a feedback ammeter with eight current ranges.

b. Autorangeing Circuit. The autorangeing circuit senses the magnitude of the display so as to trigger the range changing circuits and cycle from 10^{-2} through 10^{-9} amperes full scale.

c. Analog-to-Digital Converter. The A/D converter is a dual slope, integrating type converter with medium conversion rate, cold cathode readout tubes, BCD outputs and optional external controls.

3-2. PICOAMMETER.

a. Operation. The picoammeter consists of a linear dc amplifier with a 1 volt full scale sensitivity. The amplifier provides an analog output up to 2 volts for 100% overrange display. The RANGE resistors are connected across the feedback of the amplifier. A simplified diagram of a feedback ammeter is shown in Figure 9.

b. Circuitry. The amplifier input stage is a pair of insulated-gate, field-effect transistors (IGFET) designated Q1201 and Q1202 connected in a differential configuration. The circuit designated 23430B is a special overload protection circuit on the Input FET board. The gate of Q1201 is connected to the input through 10 Megohms while the gate of Q1202 is referenced to ground. Potentiometer R1238 is an internal COARSE ZERO adjustment. Potentiometer R1202 is an internal BALANCE control. Transistors Q1203-Q1204 form a second differential amplifier stage. Potentiometer R1207 is a front panel ZERO adjustment. Transistors Q1205 and Q1206 (emitter-follower) provide sufficient gain for the analog output and A/D converter. The analog output is connected through R614 (499Ω) to the dc amplifier output (the junction of R1215 and D1212). The full scale current sensitivity is determined by the RANGE resistor connected across the feedback. The RANGE resistance R_F is composed of a fixed resistance R_1 plus a calibration adjustment resistance R_2 as shown in Figure 11. The RANGE resistors are arranged in "parallel" such that, on the "10⁻²" range, all eight RANGE resistors are connected. Range selection and zero check are performed using reed relays which are electrostatically shielded from the high impedance circuitry to prevent coupling of switching transients. The FILTER Switch (S1201) provides additional damping on the 10⁻⁷, 10⁻⁸, and 10⁻⁹ ampere ranges with an additional 40 dB rejection of 60 Hz frequency. With the FILTER Switch set to "IN", the A/D conversion rate is set to 1 reading per second maximum.

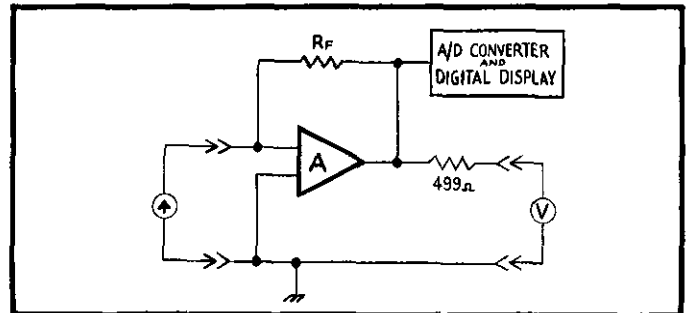

FIGURE 9. Feedback Ammeter.

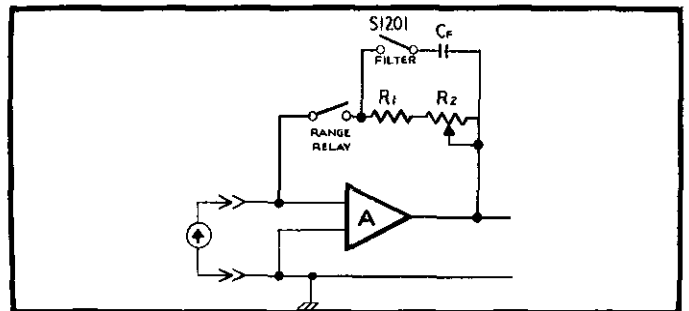

FIGURE 10. Range Calibration.

3-3. AUTORANGING.

a. Operation. The autoranging circuit operates from the BCD outputs of the A/D converter. If the reading is less than 0-1-0-0, then an "Under-range" command is generated and the range relays are operated to "Down-range" to a more sensitive range. If the reading is greater than 1-9-9-9, then an "Over-range" command is generated and the range relays are operated so as to "reset" and then "Down-range". If the HOLD/AUTOMATIC Switch is set to "HOLD", the autoranging circuit is inhibited and the range will hold regardless of the current being measured.

b. Circuitry. Integrated circuits QA703, QA704A, and QA704B code the BCD outputs to generate "Under-range" and "Overrange" commands. The "Buffer-Store" command is delayed for approximately 5 microseconds by Mono stable gates QA705A and QA705B, to allow signals to settle. The range counter gates (QA801, QA802) is a three-bit binary counter ("000" corresponds to 10^{-2} , "111" corresponds to 10^{-9} ampere). The output of the range counter is decoded by gates QA803, QA804 and QA805 into an "eight-line" code. The eight-lines are encoded by gates QA806 and QA807 to yield BCD range information. Gates QA809 and QA810 store the range information. The range display tube is driven by transistors Q901 through Q908. Gates QA901, QA902 and QA903 drive transistors Q909 through Q915 to operate the read relays.

3-4. ANALOG-TO-DIGITAL CONVERTER OPERATION.

a. General. A detailed block diagram of the A/D converter is shown in Figure 13. The analog-to-digital converter operates using a dual slope integration technique which has inherent line frequency noise rejection. The analog signal is applied to the integrator for one complete line frequency cycle. The analog signal is then removed from the integrator input. The voltage on the integrator is then driven to zero to complete the voltage-to-time conversion. The time interval to reach a "Zero Crossing" is counted and displayed on the "Readout" in proportion to the original analog signal. The sequence is then repeated for a second reading. A Timing Diagram is shown in Figure 8.

b. Circuits. The A/D Converter is composed of nine major circuits which perform the analog-to-digital conversions and provide various control commands.

1. Oscillator or Clock
2. BCD Counter
3. Delay Hold
4. Program/Decoder
5. Integrator
6. Zero Crossing Detector
7. Buffer/Storage Register
8. Decoder/Driver
9. Numerical Readout

c. Oscillator or Clock. The Oscillator produces pulses at a rate of 120 kilohertz for Electrometer using 60 Hz line power. (The 50 Hz units have a pulse rate of 100 kilohertz).

d. BCD Counter. The BCD Counter counts the Clock pulses with a total range of 5000 counts. The Counter is composed of 4 individual counters designated 1, 10, 100, and 1000.

e. Delay Hold. The Delay Hold circuit controls the DISPLAY RATE function and external Hold and Trigger commands as shown in Figure 14. It determines the length of time between A/D conversions when the front panel DISPLAY RATE Control is set to any position other than MAX. The clock is stopped at the beginning of the ZERO (2) period for a time determined by the rotation of the DISPLAY RATE Control. It ensures that when the Hold 2 is grounded the conversion in process will be completed and new data will be stored in the output storage register. Then the clock will be inhibited at the beginning of the ZERO period (2). The instrument will remain in this condition indefinitely until Hold 2 is released or until Trigger is shorted to ground. After conversion, the instrument will again be inhibited at the beginning of the period (2). If both Switches S₁ and S₂ are closed, the conversion cycle works in the following manner. After the previous conversion has been completed, the leading edge of the program command (2) resets the flip-flop. In this new condition Q is high and, therefore, the clock gives no output. At that time, the unijunction timer begins its cycle and, after the appropriate time, produces a pulse that sets the flip-flop. This changes Q to a low state and a new conversion cycle begins. After the reading has been completed, the (2) command again resets the flip-flop and the timer again issues a new pulse to set the flip-flop.

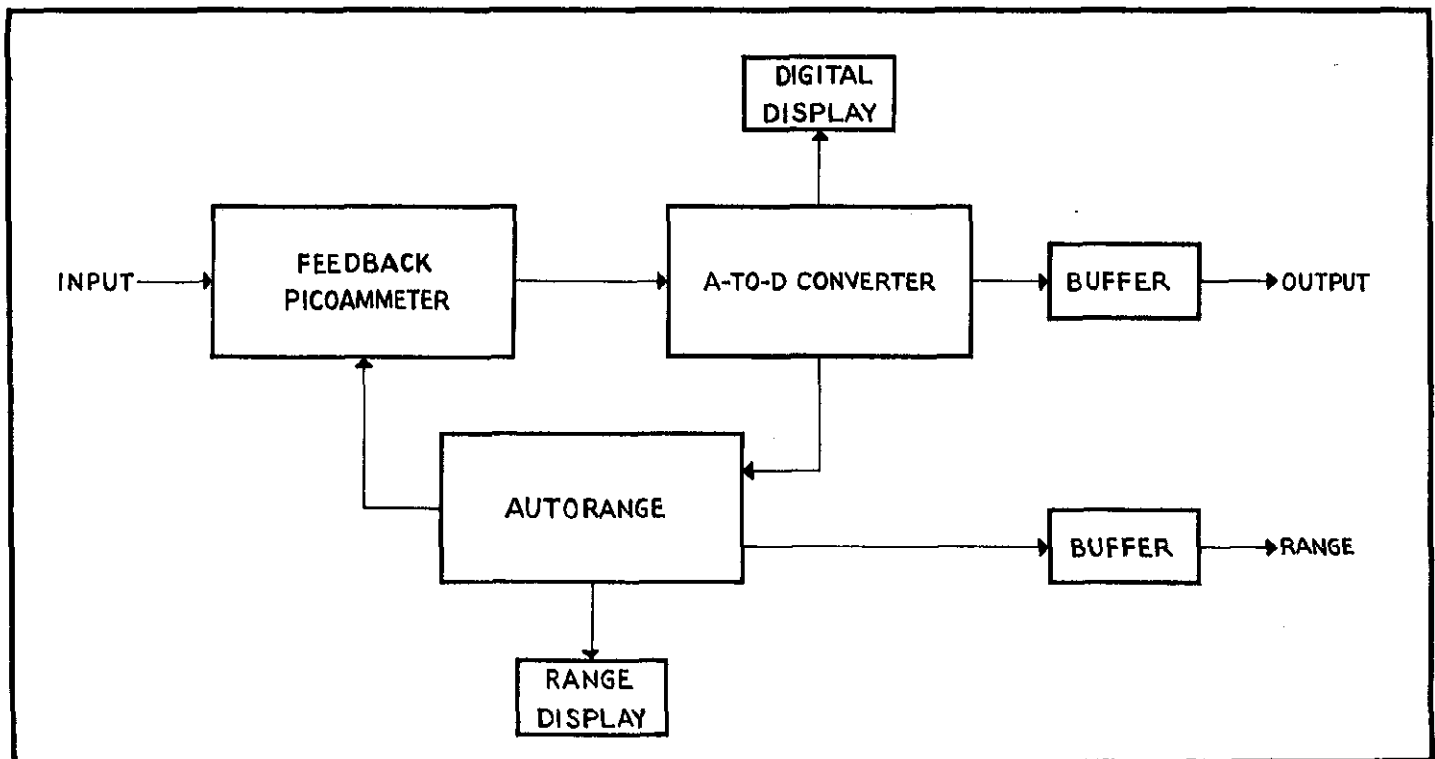

FIGURE 11. Overall Block Diagram.

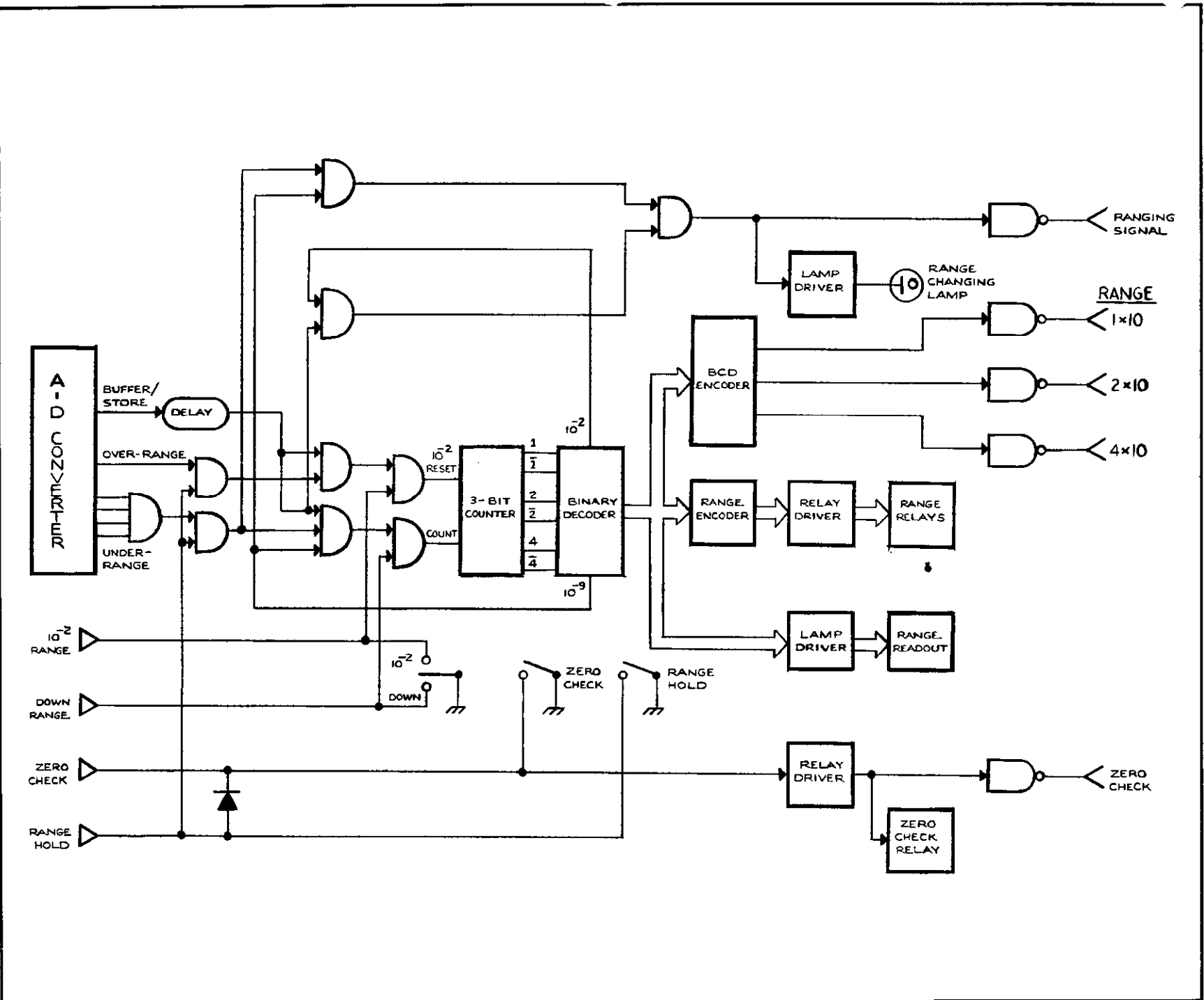

FIGURE 12. Autorangeing Block Diagram.

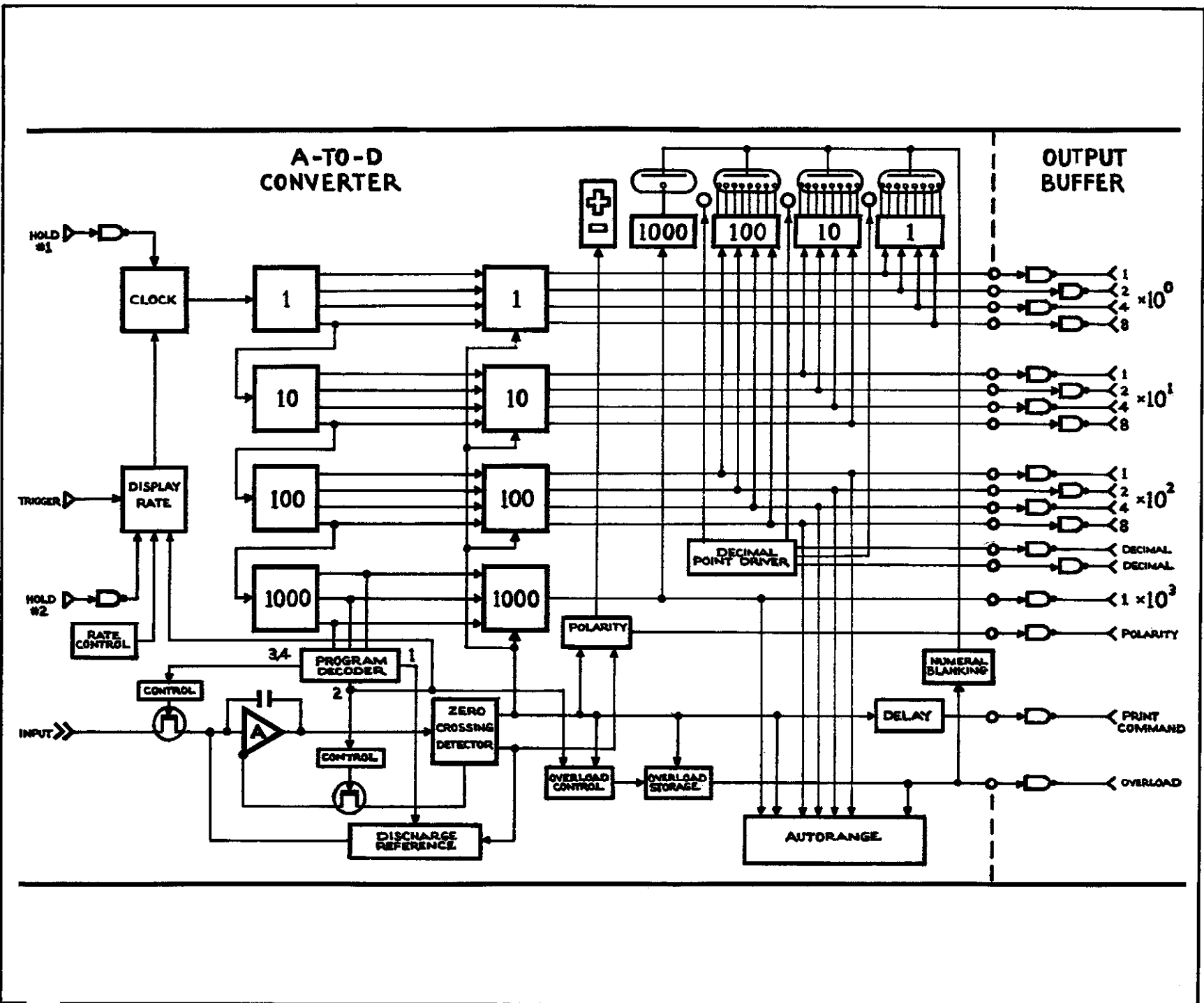

FIGURE 13. A-to-D Converter Diagram.

f. Program/Decoder. The Program/Decoder circuit produces event commands to control the overall sequence of events for a complete A/D conversion.

g. Integrator. The Integrator circuit operation is composed of three periods.

1. Zero Period. During this period the integrator amplifier is zeroed by the closure of switch S_b . Switches S_a , S_c , and S_d are open to prevent integrator charging as shown in Figure 15.

2. Integration Period. During this period, switch S_b , S_c , and S_d are open. Switch S_a is closed to permit charging by the analog voltage for a period of one line cycle.

3. Discharge Period. During this period, switch S_a is open to prevent further charging by the analog signal. Either switch S_c or S_d is closed to drive the Integrator voltage to zero. A reference current of opposite polarity to the input current is applied through either switch S_c or S_d . The Discharge Period ends when the Zero Crossing Detector circuit detects a zero Integrator output.

h. Zero Crossing Detector. The Zero Crossing Detector circuit provides a "High" or "Low" level output depending on the polarity of the detected input. Refer to Table 3-1 for a description of voltage outputs.

TABLE 3-1.
Zero Crossing Detector Output Levels.

M	N	B	C
0V	-0.5V	+1.5V	0V
0V	+3.5V	0V	+1.5V

i. Buffer/Storage Register. The Buffer/Storage Register is composed of "flip-flops" arranged to copy the states of the various BCD counters. The Buffer/Storage Register requires a Buffer Store command before any information can be transferred. The "flip-flop" circuits provide coded information for Decoder/Driver and the BCD outputs.

j. Decoder/Driver. The Decoder/Driver circuit decodes the BCD information from the Storage Register into ten-line decimal code. The Driver circuit then drives the proper numeral in each of the Numerical Readout tubes.

k. Numerical Readout. The Numerical Readout consists of four numerical indicators and one polarity indicator driven by the Decoder/Driver, Polarity and Overload Drivers.

1. Summary of Operation. The operation of the A/D Converter can be described by considering a typical conversion cycle.

1. The Oscillator or Clock provides pulses at a rate of 120 kilohertz.

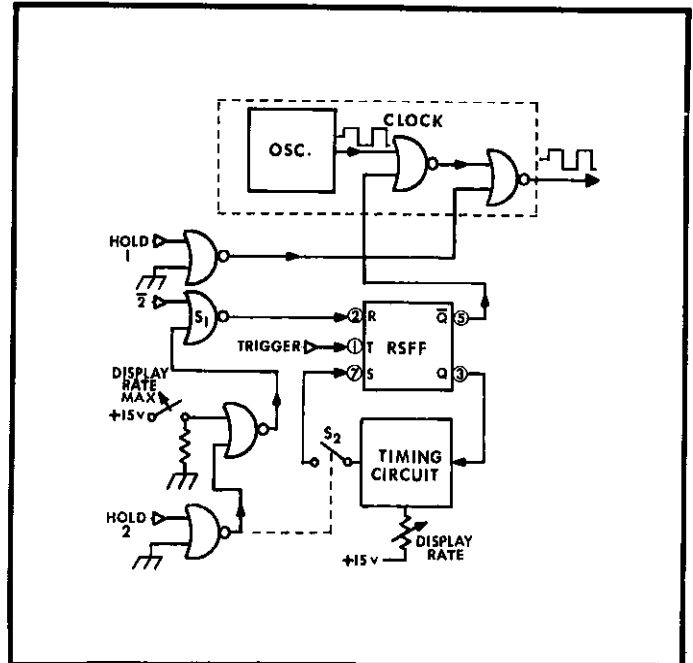

FIGURE 14. Delay Hold Diagram.

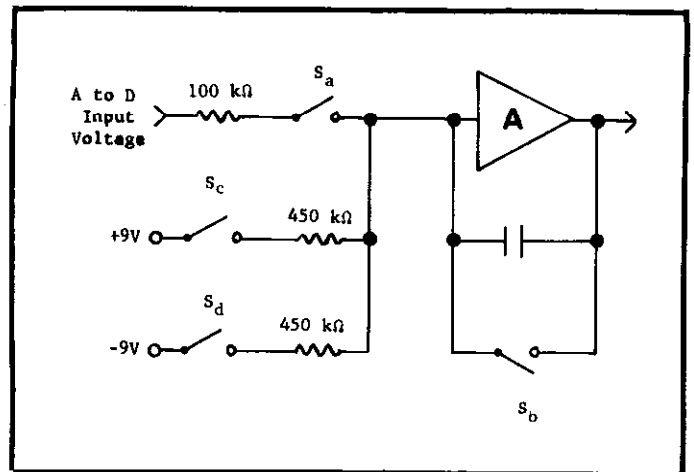

FIGURE 15. Integrator Block Diagram.

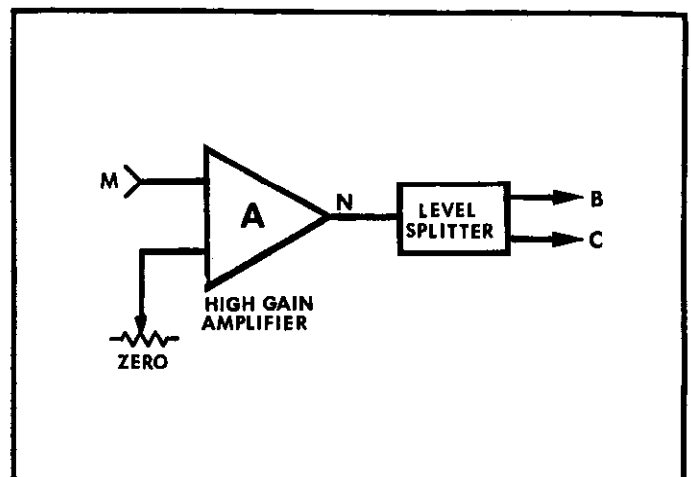

FIGURE 16. Zero Crossing Detector.

2. The Delay Hold circuit gates the output of the Oscillator depending on the state of the "RS flip-flop" and the "Hold 1" control line. A unijunction timing circuit provides a delay period before a conversion is initiated. The time delay is selected by the front panel DISPLAY RATE Control.

3. The BCD Counter serves as a master timing control for the A/D conversion cycle. The timing is accomplished by the "1000" counter which has five coded states, namely 0, 1, 2, 3, and 4.

4. The Program/Decoder controls the sequence of commands based on the coded states from the BCD Counter. The decoded commands are described as shown in Table 3-2. The "2" command initiates the integrator ZERO period which removes any residual charge on the integrator capacitor. The "3,4" command initiates the INTEGRATE period which permits an integration of the analog signal. At the end of the INTEGRATE period, the "0,1" command initiates the COUNT period.

TABLE 3-2.

Command	Function
2	ZERO
3,4	INTEGRATE
0,1	COUNT

5. When the "3,4" command is given, the integrator is charged by the analog signal for a period of 1 line cycle of 16.67 milliseconds.

6. When the "0,1" command is given, the analog signal is removed and the integrator output is driven to zero by a reference current. The Zero Crossing Detector senses a zero crossing of the Integrator output and removes the reference current. The Detector provides outputs as shown in Table 3-1. The +1.5 volt levels are provided for control of the Integrator and Polarity Storage Register. A pulse command is also produced to initiate a Buffer/Store and Print Command output.

7. When the Buffer/Store command is given, the Buffer/Storage Register copies the BCD Counterstates at that instant of time. The BCD coded information in the Register is then available for the Decoder/Driver and external printout.

8. The Decoder/Driver decodes the Buffer/Storage output and drives the Numerical Readout for a digital display.

9. The BCD Output information is available at the Model 4401 Buffer Card outputs in the form of positive (+10 volt) true logic (1-2-4-8 BCD Code).

10. The conversion cycle is completed when the BCD Counter reaches 2000 counts and the Program/Decoder provides a "2" command to initiate a new conversion cycle.

11. The Unijunction Timing Circuit will initiate the ZERO period after a present time delay controlled by the front panel DISPLAY RATE Control.

3-5. ANALOG-TO-DIGITAL CONVERTER CIRCUITRY.

a. General. The circuits described in this section are located on the various Sub-Assemblies listed below and in Table 7-2 of Section 7.

1. Oscillator Board, PC-217.
2. Integrator Board, PC-219.
3. Display/Overload Board, PC-241.
4. Readout Board, PC-229.
5. Polarity Board, PC-207.
6. Output Buffer Board, PC-218.
7. Output Buffer Board, PC-209.

b. Oscillator Board. The Oscillator Board contains portions of three circuits: the Oscillator (clock) circuit, the Delay/Hold circuit, and the Discharge-Voltage Current Source circuit.

1. Oscillator Circuit. Transistor Q501, crystal Y501, and phase shift capacitors C501, and C502 form a "Colpitts" type oscillator. Capacitors C503 and C504 are used for trimming the oscillator frequency. The output is taken from the collector of transistor Q510 which is a common emitter gain stage used for squaring the output. Transistor Q507 serves as an emitter-follower to reduce output impedance.

2. Delay/Hold Circuit. There are three major components in the Delay/Hold circuit: an "RS" type flip-flop circuit, a "Unijunction" timing circuit and a "Hold" gate circuit.

a. "RS" Type Flip-Flop Circuit. The flip-flop gates the output of the clock depending on the inputs at pins R and S. The RS flip-flop is constructed of gates QA501B and QA501C. The pins are identified as shown in Figure 16.

b. "Unijunction" Timing Circuit. The unijunction timing circuit determines the time delay between conversion cycles to obtain the desired conversion rate as determined by the front panel DISPLAY RATE Control. The circuit is composed of transistors Q513 and Q514, timing capacitor C507, and timing resistors R532 and R1269 (DISPLAY RATE Control potentiometer located on the front panel.

c. "HOLD" Gate Circuit. (Refer to Figure 16 for identification of switches S₁ and S₂). The "HOLD" gate circuit is composed of gates QA501A, QA501D, and QA502 (A, B, C, and D). Switch S₁ is gate QA501A and is controlled by either the "HOLD 2" external line or the "MAX" position on the DISPLAY RATE Control. Switch S₂ is transistor Q513 which is controlled by either the "Q" output of the flip-flop or the "HOLD 2" external line. The "HOLD 1" circuit is composed of gates QA502B and QA502C.

3. Discharge-Voltage Current Source Circuit. The positive current source composed of transistors Q502 and Q506 delivers a constant current of +7.5 milliamperes to drive a 9-volt zener diode D602 (located on the Integrator Board, PC-246) when +REF Terminal (Pin 13) is greater than +0.7 volt. The negative current source composed of transistors Q508 and Q509 delivers a constant current of -7.5 milliamperes to drive a 9-volt zener diode D601 (also located on the Integrator Board, PC-219).

c. Integrator Board. The Integrator Board consists of two major circuits: the Integrator circuit and the Zero Crossing Detector circuit.

1. **Integrator Circuit.** The operation of the Integrator is controlled by the positions of switches S_a , S_b , S_c , and S_d . Switch S_a is transistor Q605. Switch S_b is transistor Q606. Transistors Q601 through Q604 are control circuits arranged to turn off the proper FET switches depending on the signals at pins 11 and 12. The integrator amplifier consists of transistors Q607 and Q608 and integrated circuit QA601. The feedback capacitor is C603. Switches S_c and S_d (located on the Oscillator Board, PC-217) control the current for 9-volt zener diodes D601 and D602. Resistors R602 through R611 are full-scale calibration resistors.

2. **Zero Crossing Detector Circuit.** (Refer to Figure 18). The high gain amplifier is composed of cascaded amplifiers QA602 and QA603. The zero adjustment network consists of resistors R645, R646, R648, R649, and R650, and diodes D611 and D612. Transistor Q609 and other components form a 6-volt supply for QA603 and the zero circuit. The level-splitter circuit consists of diodes D613 and D614, resistors R651, R652, and R653 and gates QA604 (A, B, C).

d. Display/Overload Board. The Display/Overload Board contains a BCD Counter ("1000" counter), a Program Decoder circuit, and an Overload Control circuit.

1. The BCD Counter is composed of "J-K" flip-flop circuits QA301 and QA302.

2. The Program Decoder circuit is composed of gates QA303C and QA303D (3,4 Command) and QA304A, QA304B, QA304C, QA304D, QA305A, QA305B, QA305C, QA305D, QA303E, QA306A, QA306B, and QA306C (0,1 & 2 Commands).

3. The Overload Control circuit provides an overload signal if a zero crossing does not occur in the Discharge Period (0,1). It controls the Numerical Blanking circuit and provides an Overload Print signal.

e. Readout Board. The Readout Board contains Decade Counter circuits, Buffer Storage circuits, and Decoder Driver and Display circuits.

1. **Decade Counter Circuits.** Each decade counter is composed of four J-K flip-flops. Circuits QA401 through QA406 are Dual J-K Flip-Flop integrated circuits.

2. **Buffer Storage Circuits.** The Buffer Storage register is composed of Dual J-K Flip-Flop integrated circuits QA409 through QA414.

3. **Decoder Driver Circuits.** QA415, QA416, and QA417 are Decimal Decoder Driver integrated circuits.

4. **Display Circuits.** V401, V402, and V403 are Readout Tubes for Units, Tens, and Hundreds respectively.

f. Polarity Board. The Polarity Board contains various circuits which are controlled by signal "B" and "C" from the Zero Crossing Detector signal as shown in Figure 16.

1. **Polarity Indicator Control Circuit.** This circuit drives the Polarity Indicator DS201 to provide a Polarity display. QA201A and QA206A are J-K Flip-Flop circuits which control transistors Q201 and Q202.

2. **Polarity Print Signal Circuit.** The Polarity Print signal is determined by the Q output of J-K flip flop QA206A.

3. **Discharge Voltage Polarity Control Circuit.** The +REF Control signal is determined by QA201A and gate QA204A. The -REF Control signal is determined by QA202A, QA203A, QA203B, QA202B, QA202C, QA203C, QA203D, and QA204B.

4. **Buffer Store Command Circuit.** The Buffer Store command is provided by J-K flip QA201B and gates QA204C and QA207A.

5. **Overload Blanking Circuit.** A portion of the Overload Blanking circuit QA204D, QA206B, and QA207B is located on the Polarity Board. The remainder of the circuit is located on the Display/Overload Board PC-241.

g. Output Buffer Board, PC-218. This board contains 15 buffer circuits to provide BCD Data and Overload and Polarity Print signals. Buffer circuits "A" through "P" consist of transistor buffer stages as shown in Figure 17.

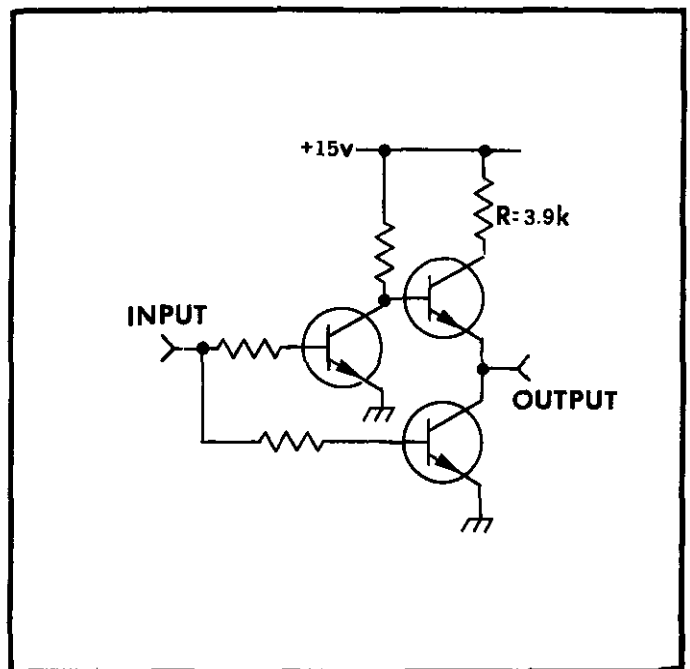

FIGURE 17. Model 4401 Buffer Stage.

h. Output Buffer Board, PC-209. This board contains six buffer circuits and various gate circuits to provide Print Command and Range Signal Print signals.

1. Buffer Circuits. Buffer circuits "A" through "E" provide BCD Range information.

2. Print Command Circuits. Buffer circuits composed of transistors Q1101, Q1102, Q1104, Q1105, Q1106, and Q1107 provide Print Command signals as determined by gates QA1101 (A, B, C, and D) and QA1102 (A, B, C, and D).

3. Range Signal Circuit. Transistors Q1108, Q1109, and Q1110 comprise a Range Signal Buffer stage controlled by the Range Signal.

4. Reference Voltages. A High and Low Reference voltage is provided by resistor divider R1114, R1115, and R1116. The voltages are +8 volts (High) and +2 volts (Low).

3-6. POWER SUPPLIES. (Schematic 23448E).

a. ±15 Volt Supply. The ±15 volt supplies tap ac power from a secondary of transformer T101. Diodes D103, D105, D107 and D108 and capacitors C104 and C105 compose a full-wave rectifier with filtering. Transistors Q114 and Q115 form a differential amplifier which compares the voltage at R115 with the voltage of zener diode D110. The difference voltage is amplified by transistor Q109 and fed to Darlington transistor pair, Q106 and Q107, which series regulate the output voltage. Transistors Q116 and Q117 form a differential amplifier which compares the voltage at R123 with respect to I_0 . The difference voltage is amplified by transistor Q113 and fed to Darlington transistor pair, Q110 and Q111, which series regulate the -15 volt output. Transistors Q108 and Q112 limit the output current to about 200 milliamperes.

b. +3.6 Volt Supply. The +3.6 volt supply taps ac power from a secondary of transformer T101. Diodes D101 and D102 and capacitor C101 form a full-wave rectifier with filtering. Transistor Q105 amplifies the difference between the +3.6 volt output and a reference voltage derived from the +15 volt supply and determined by resistors R103 and R104. The difference voltage is amplified by transistor Q104 which drives a Darlington transistor pair, Q101 and Q102. The Darlington pair series regulates the +3.6 volt output. Transistor Q103 limits the output current to about 3 amperes.

c. +170 Volt Supply. The +170V supply taps ac power from a secondary of transformer T101. Diode D111 and capacitor C112 form a half-wave rectifier with filtering. Transistor Q119 amplifies the voltage developed by the resistor divider R128 and R129. The output of Q119 controls the series regulator transistor Q118 to maintain the +170 volt output. When the electrometer is overloaded, and overload signal drives transistor Q120 which in turn controls the voltage at the base of transistor Q119. The circuit composed of diode D112, transistor Q120, and resistors R130, R131 and R132 reduces the +170 volt output to +80 volts when overloading occurs. Grounding the overload input turns off transistor Q120 causing diode D112 to conduct and drive Q119. The reduced +80 volt output causes blanking on all Numerical Readout Tubes connected to the +170 volt supply.

d. +210 Volt Output. The +210 volt supply is an unregulated voltage supply using the half-wave filtered voltage at diode D111 and capacitor C112.

e. +17 Volt Supply. The +17 volt supply is an unregulated voltage using the half-wave filtered voltage at diode D113 and capacitor C113.

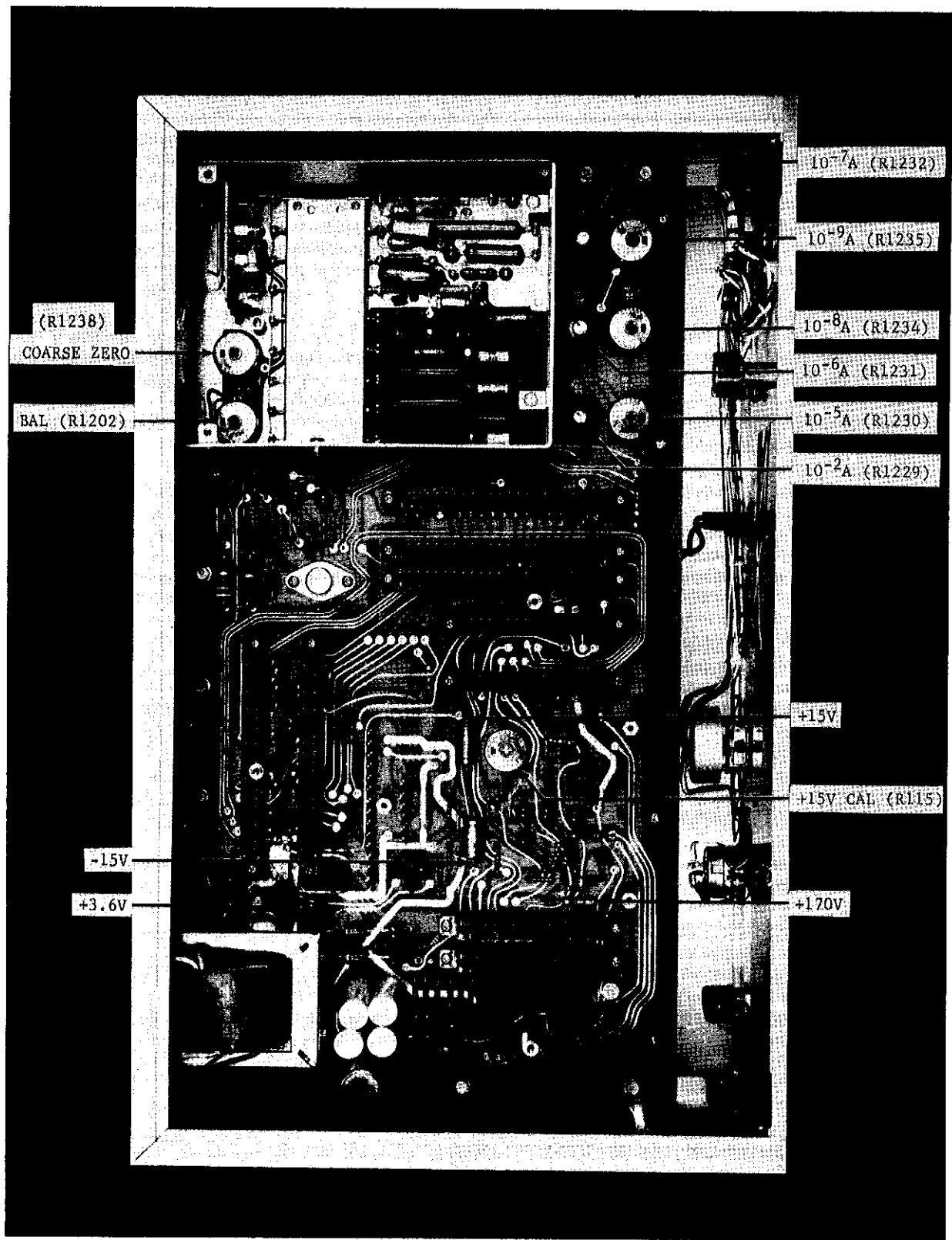

FIGURE 18. Chassis, Top View.

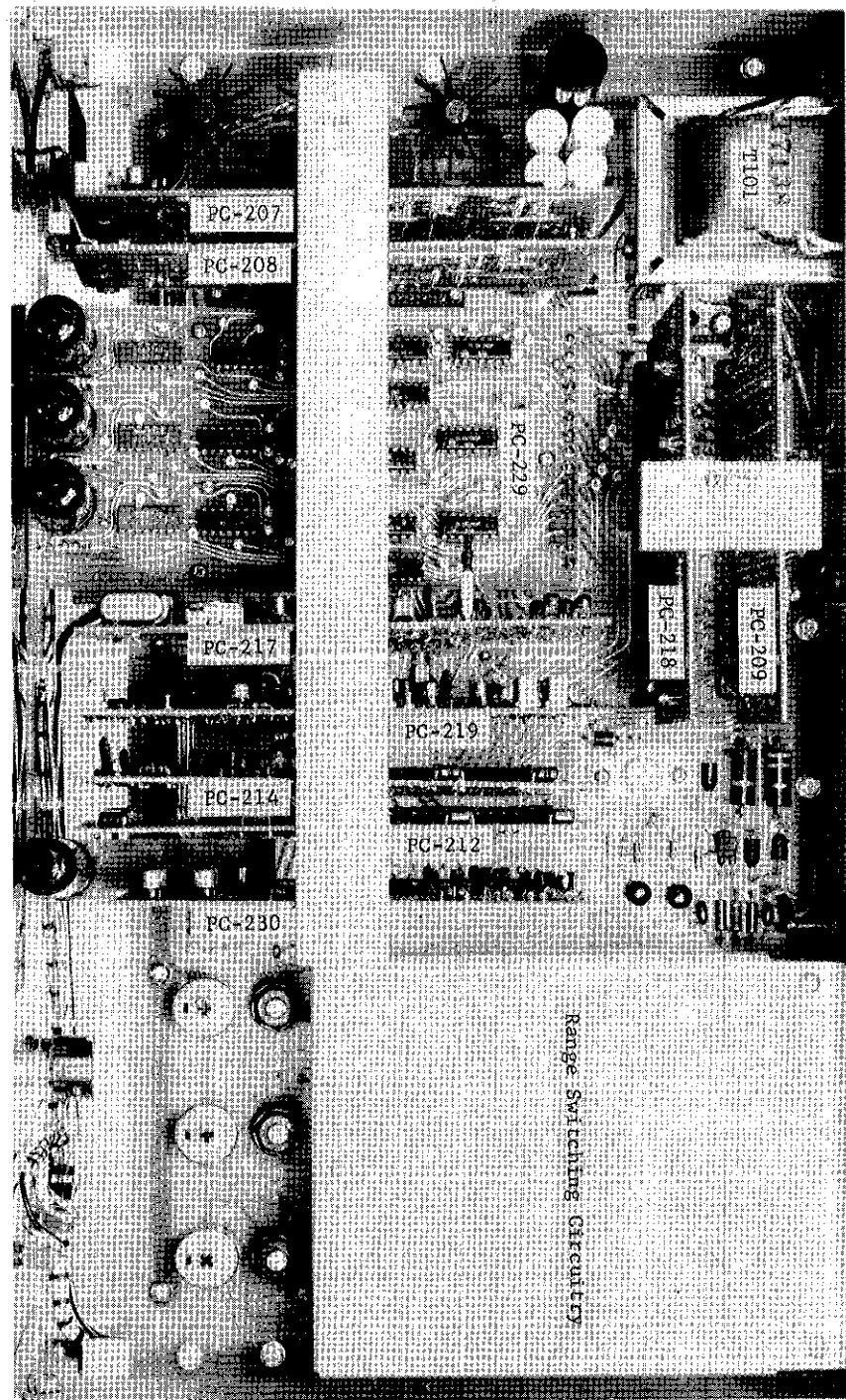

FIGURE 19. PC Board Locations.

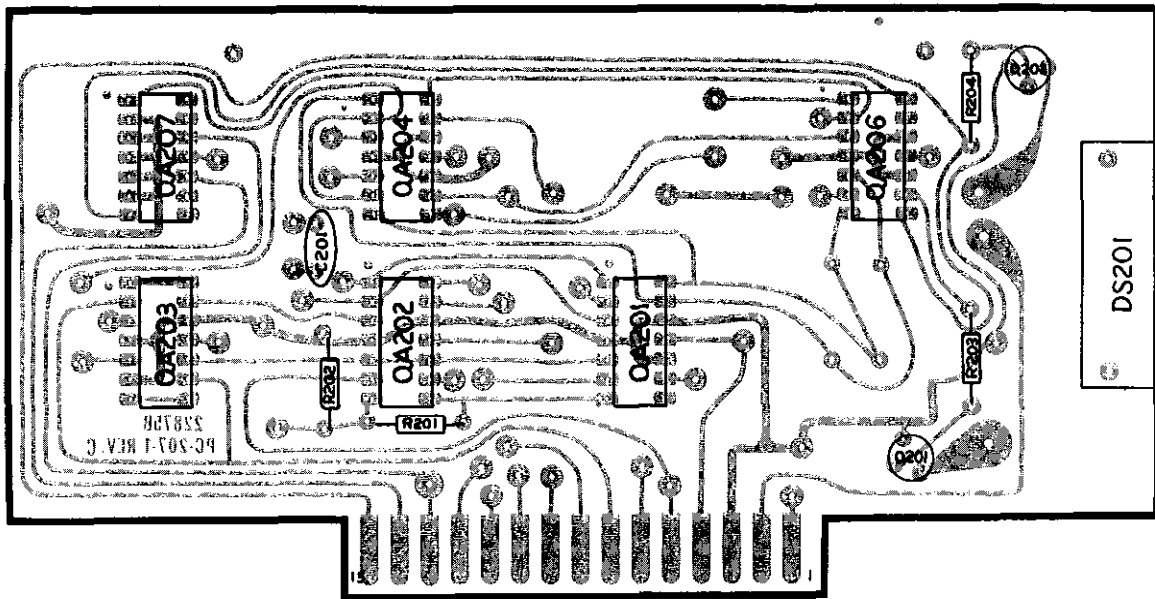

FIGURE 20. Component Layout, PC-207.

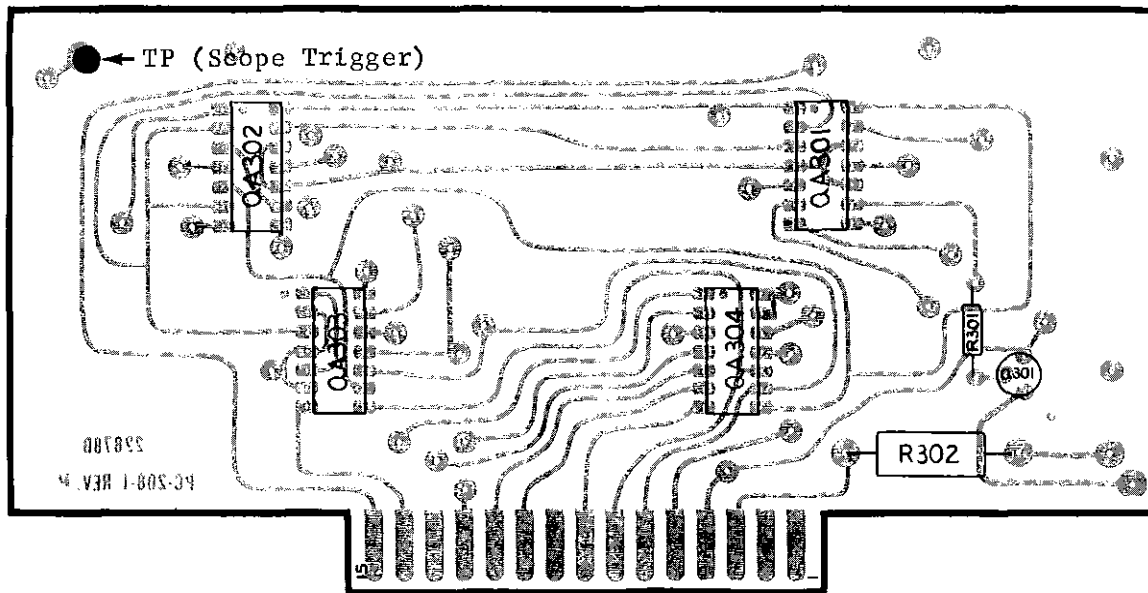

FIGURE 21. Component Layout, PC-208.

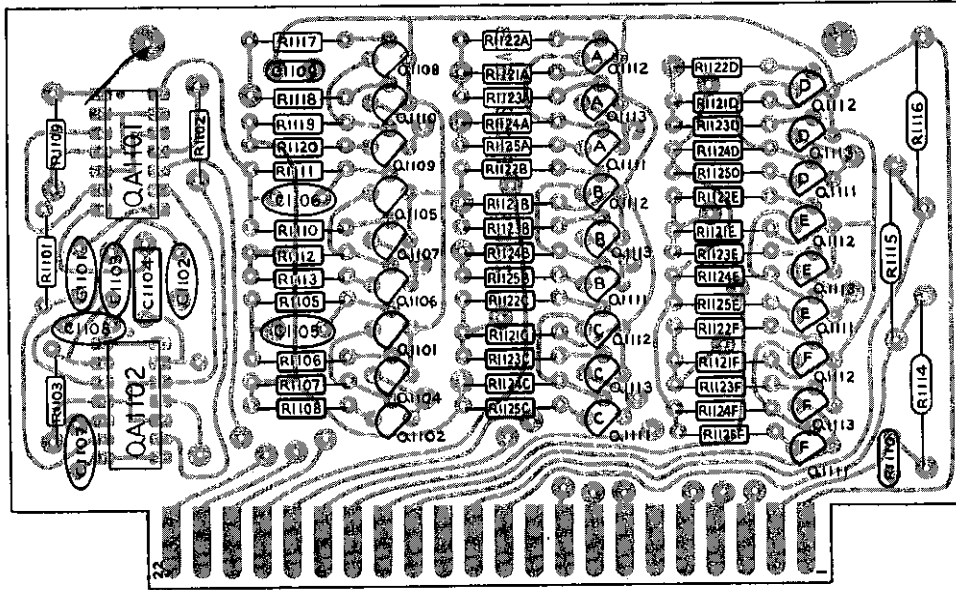

FIGURE 22. Component Layout, PC-209.

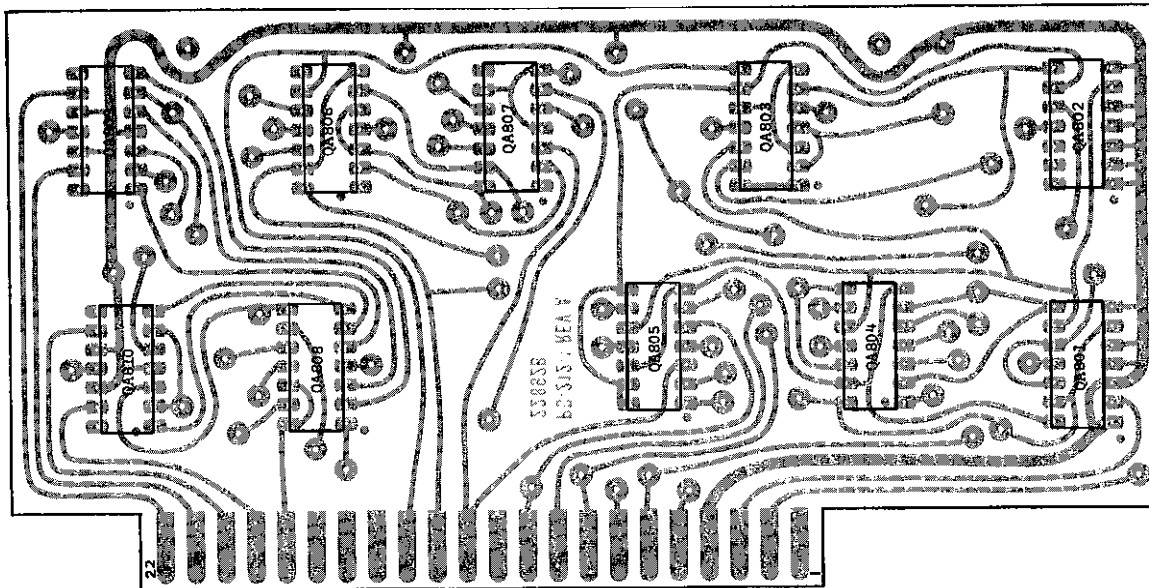

FIGURE 23. Component Layout, PC-212.

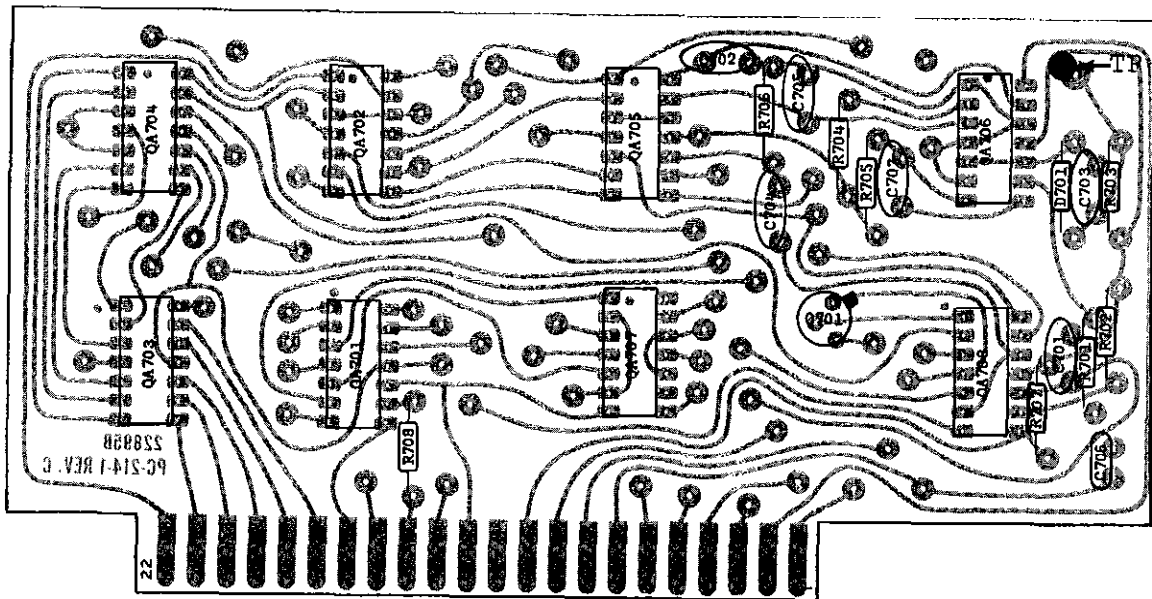

FIGURE 24. Component Layout, PC-214.

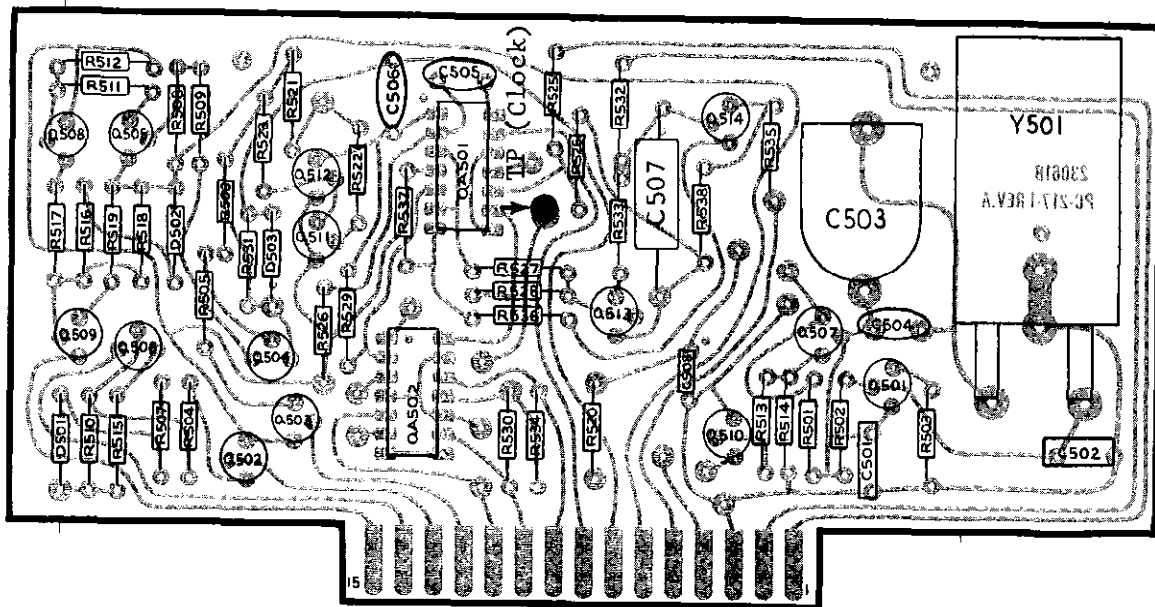

FIGURE 25. Component Layout, PC-217.

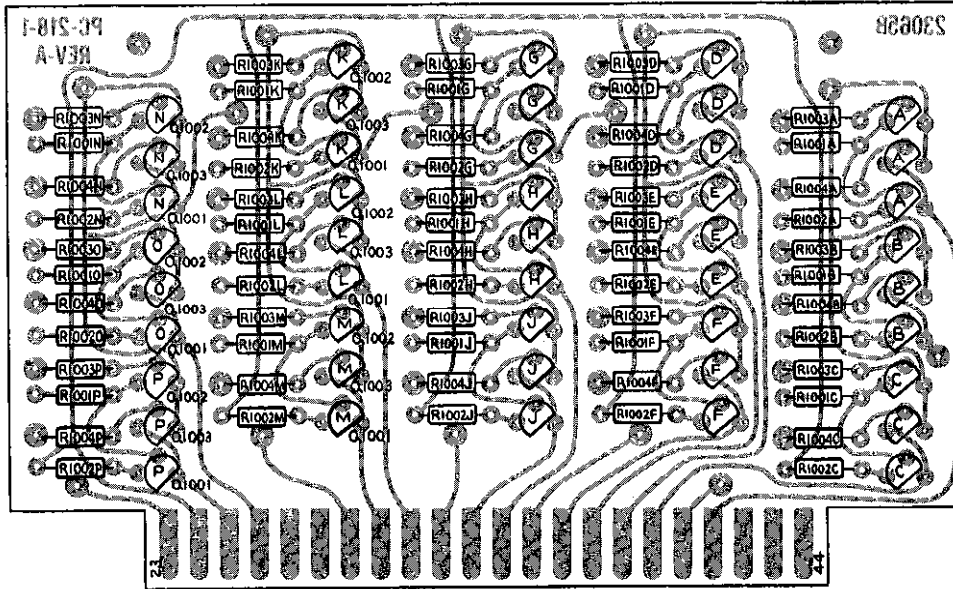

FIGURE 26. Component Layout, PC-218.

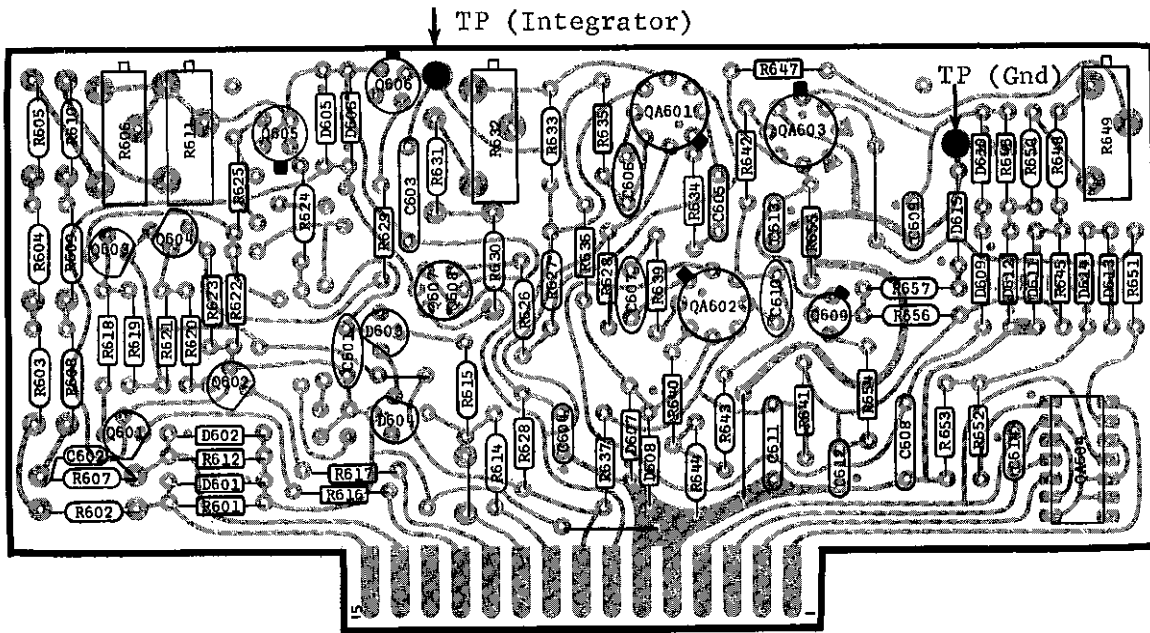

FIGURE 27. Component Layout, PC-219.

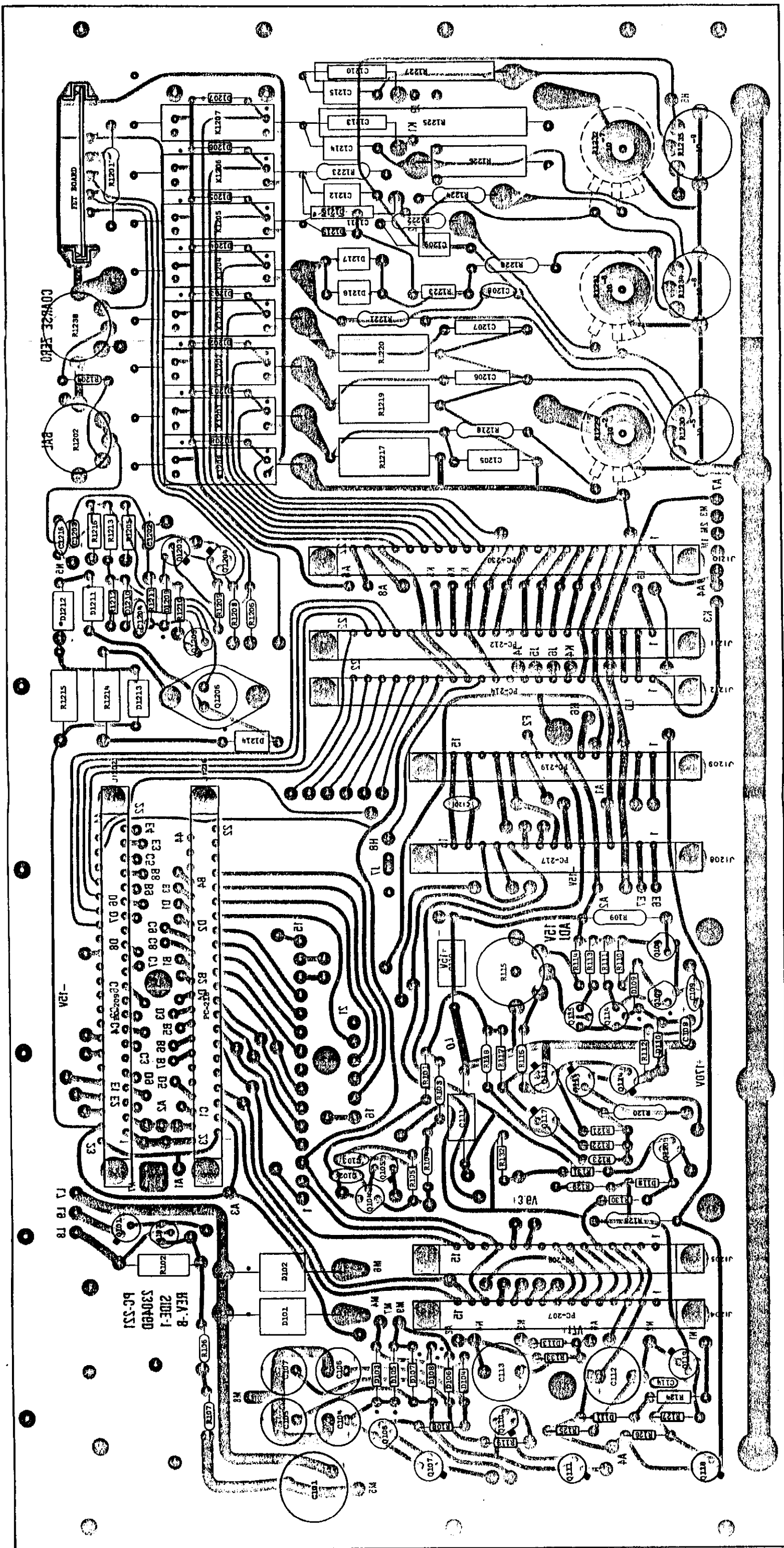

Figure 28. Component Layout, PC-221

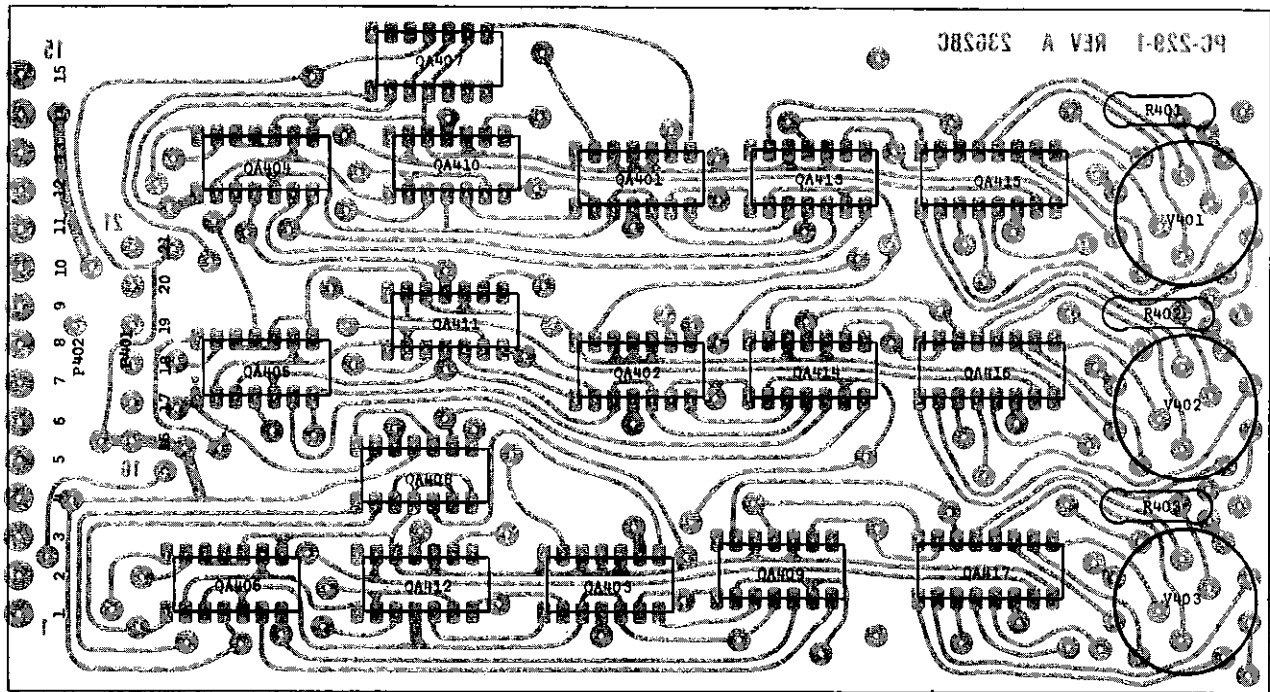

FIGURE 29. Component Layout, PC-229.

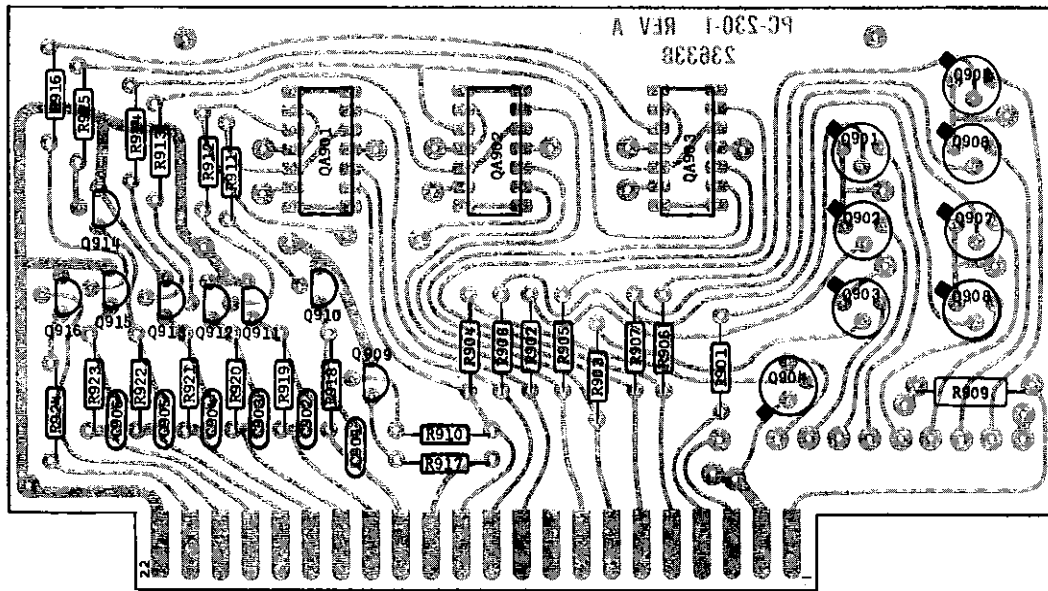

FIGURE 30. Component Layout, PC-230.

SECTION 4. REPLACEABLE PARTS

4-1. REPLACEABLE PARTS LIST. This section contains a list of components used in this instrument for user reference. The Replaceable Parts List describes the individual parts giving Circuit Designation, Description, Suggested Manufacturer (Code Number), Manufac-

turer's Part Number, and the Keithley Part Number. Also included is a Figure Reference Number where applicable. The complete name and address of each Manufacturer is listed in the CODE-TO-NAME Listing following the parts list.

TABLE 4-1.
Abbreviations and Symbols

A	ampere	F	farad	Ω	ohm
CbVar	Carbon Variable	Fig.	Figure	p	pico (10 ⁻¹²)
CerD	Ceramic Disc	GCb	Glass enclosed Carbon	PC	Printed Circuit
Cer Trimmer	Ceramic Trimmer	k	kilo (10 ⁻³)	Poly	Polystyrene
Comp	Composition	μ	micro (10 ⁻⁶)	Ref.	Reference
DCb	Deposited Carbon	M	Meg (10 ⁶)	TCu	Tinner Copperweld
Desig.	Designation	Mfr.	Manufacturer	V	volt
EAL	Electrolytic, Aluminum	MtF.	Metal Film	W	watt
ETB	Electrolytic, tubular	My	Mylar	WW	Wirewound
ETT	Electrolytic, tantalum	No.	Number	WWVar	Wirewound Variable

4-2. ELECTRICAL SCHEMATICS AND DIAGRAMS. Schematics and diagrams are included to describe the electrical circuits as discussed in Section 3. Refer to Table 4-2 which identifies all schematic part numbers included.

Sales Service Department, Keithley Instruments, Inc. or your nearest Keithley representative.

4-3. HOW TO USE THE REPLACEABLE PARTS LIST. This Parts List is arranged such that the individual types of components are listed in alphabetical order. The parts for the instrument's Main Chassis are listed followed by printed circuit boards and other sub-assemblies.

b. When ordering parts, include the following information.

1. Instrument Model Number.
2. Instrument Serial Number.
3. Part Description.
4. Schematic Circuit Designation.
5. Keithley Part Number.

4-4. HOW TO ORDER PARTS.

c. All parts listed are maintained in Keithley Spare Parts Stock. Any part not listed can be made available upon request. Parts identified by the Keithley Manufacturing Code Number 80164 should be ordered directly from Keithley Instruments, Inc.

a. Replaceable parts may be ordered through the

TABLE 4-2.

Description	Circuit Description	Schematic Part No.
Main Chassis	PC-221	23488E
Power Supply	PC-221	23448E
Polarity Board	PC-207	23449D
Thousand Board	PC-208	23450D
Readout Board	PC-229	23451E
Oscillator Board	PC-217	23452D
Integrator Board	PC-219	23453E
Range Control Board	PC-214	23454E
Range Counter/Decoder	PC-212	23455E
Tube & Driver Board	PC-230	23456D
Output Buffer	PC-218	23457D
Output Buffer	PC-209	23481E

TABLE 4-3.
PC Board Designation Series

Series	Description	Designation	Connector	Page No.
100	Power Supply	PC-221	-	37
200	Polarity Board	PC-207	J1204	39
300	Thousand Board	PC-208	J1205	40
400	Readout Board	PC-229	J1206/J1207	41
500	Oscillator Board	PC-217	J1208	41
600	Integrator Board	PC-219	J1209	43
700	Range Control Board	PC-214	J1212	46
800	Range Counter/Decoder	PC-212	J1211	46
900	Tube & Driver Board	PC-230	J1210	47
1000	Output Buffer Board	PC-218	J1216	48
1100	Output Buffer Board	PC-209	J1202	49
1200	Main Chassis	PC-221	-	33

TABLE 4-4.
Mechanical Parts List.

Item No.	Description	Quantity Per Assembly	Keithley Part No.
1	<u>Top Cover Assembly</u>	-	17958C
-	Cover	1	17162C
-	Fastener	2	FA-54
2	<u>Bottom Cover Assembly</u>	-	17960C
-	Cover	1	17957C
-	Fastener	2	FA-54
3	<u>Angle, Rack Assembly</u>	2	14624B
4	<u>Screw, Slotted, 10 - 32 x 1/4</u>	4	-
5	<u>Front Panel</u>	1	23000C
6	<u>Chassis</u>	1	23003B

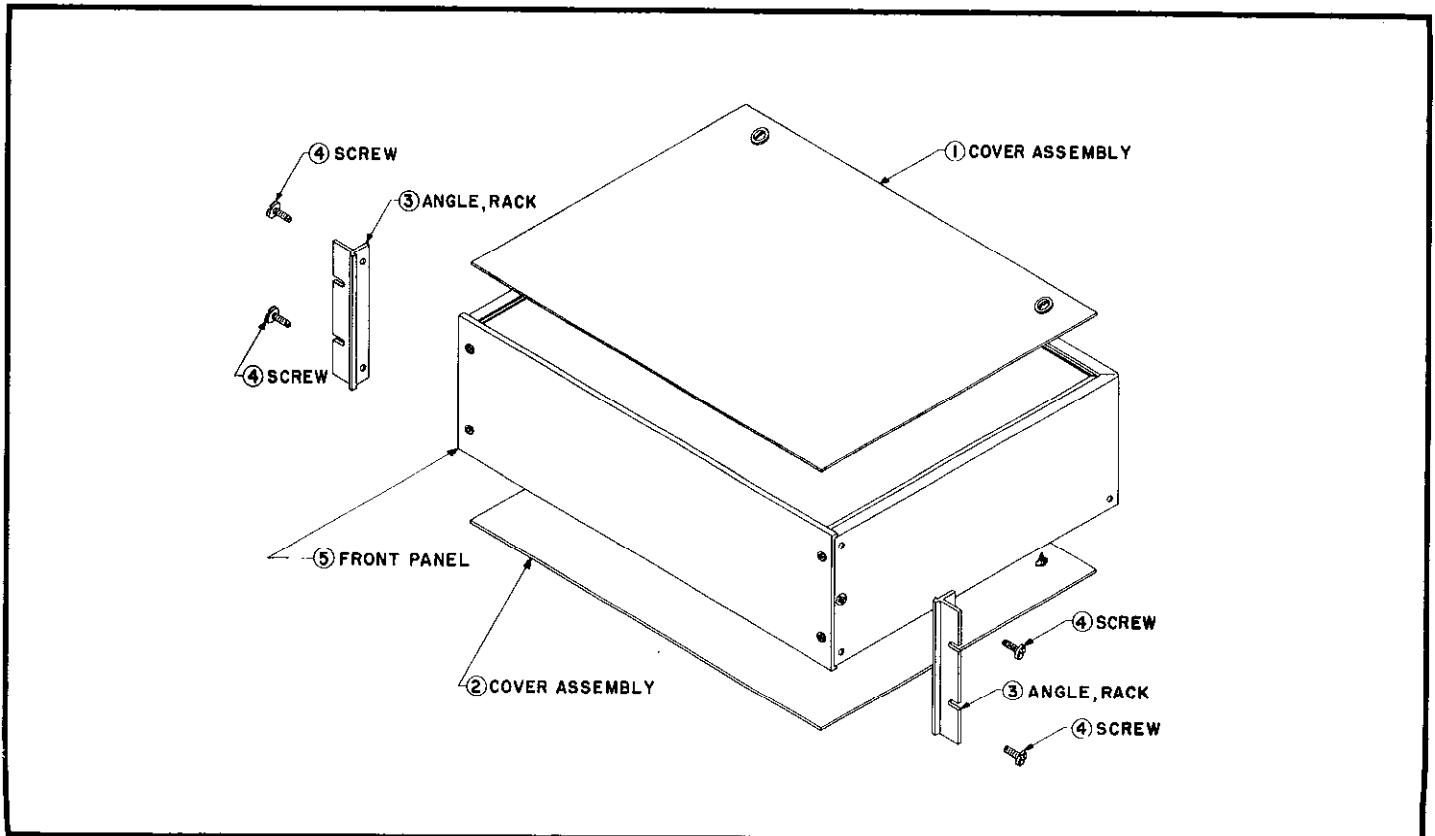

FIGURE 31. Mechanical Assembly.

MAIN CHASSIS PARTS LIST
("1200" Series, PC-221)

CAPACITORS

Circuit Desig.	Value	Rating	Type	Mfr. Code	Mfr. Part No.	Keithley Part No.	Fig. Ref.
C1201	5 pF	600 V	CerD	72982	ED-5	C22-5P	28
C1202	10 μ F	20 V	ETT	17554	TSD2-20-106	C179-10M	28
C1203	10 μ F	20 V	ETT	17554	TSD2-20-106	C179-10M	28
C1204	.0047 μ F	600 V	CerD	72982	ED-.047	C22-.0047M	28
C1205	.047 μ F	200 V	My	13050	SM1A	C143-.047M	28
C1206	.022 μ F	400 V	My	13050	SM1A	C73-.022M	28
C1207	.022 μ F	400 V	My	13050	SM1A	C73-.022M	28
C1208	.01 μ F	600 V	CerD	72982	ED-.01	C22-.01M	28
C1209	1000 pF	500 V	Poly	71590	CPR-1000J	C138-1000P	28
C1210	390 pF	500 V	Poly	71590	CPR-390J	C138-390P	28
C1211	.033 μ F	600 V	My	56289	CPS-550	C62-.033M	28
C1212	150 pF	500 V	Poly	71590	CPR-150J	C138-150P	28
C1213	3600 pF	500 V	Poly	71590	CPR-3600J	C138-3600P	28
C1214	22 pF	500 V	Poly	71590	CPR-22J	C138-22P	28
C1215	10 pF	500 V	Poly	71590	CPR-10J	C138-10P	28
C1216	.01 μ F	600 V	CerD	72982	ED-.01	C22-.01M	28

CONNECTORS

Circuit Desig.	Description	Mfr. Code	Mfr. Part No.	Keithley Part No.	Fig. Ref.
J1201**	Plug-in Contacts	80164	-	See FET Input Card	28
P1201	Printed Circuit Contacts, mate of J1201	91662	02-005-113-6-200	CS-199	28
J1202	Receptacle, 44 pins, Rear Card of Output Buffer Stage PC-209	09922	PSC 4DD22-12	CS-205	28
J1203	Not Used				
J1204	Receptacle, 15 pins, Polarity Board PC-207	09922	PSC 4SS15-12	CS-175	28
J1205	Receptacle, 15 pins, Thousand Board PC-208	09922	PSC 4SS15-12	CS-175	28
J1206	Receptacle, 6 pins, Readout Board PC-229	73690	02-006-105-6-200	CS-223	28
J1207	Receptacle, 15 pins, Readout Board PC-229	73690	02-015-105-6-200	CS-222	28
J1208	Receptacle, 15 pins, Oscillator Board PC-217	09922	PSC 4SS15-12	CS-175	28
J1209	Receptacle, 15 pins, Integrator Board PC-219	09922	PSC 4SS15-12	CS-175	28
J1210	Receptacle, 22 pins, Tube & Driver Board PC-230	09922	PSC 4SS22-12	CS-182	28
J1211	Receptacle, 22 pins, Range Counter/ Decoder Board PC-212	09922	PSC 4SS22-12	CS-182	28

MAIN CHASSIS (Cont'd)
 CONNECTORS (Cont'd.)

Circuit Desig.	Description	Mfr. Code	Mfr. Part No.	Keithley Part No.	Fig. Ref.
J1212	Receptacle, 22 pins, Range Control Board PC-214	09922	PSC 4SS22-12	CS-182	28
J1213	Receptacle, triaxial, INPUT	95712	33050-2-NT-34	CS-181	3
---	Plug, triaxial, mate of J1213	95712	30197-1	CS-141	-
J1214	Receptacle, 50 pins, PRINTER/CONTROL Connector	02660	57-40500-1	CS-221	3
---	Plug, mate of J1214	02660	57-30500-1	CS-220	-
J1215	Binding Post, LO	58474	DF21BC	BP-11B	3
J1216	Receptacle, 44 pins, Front Card of Output Buffer Stage, PC-218	09922	PSC 4DD22-12	CS-205	28
J1217	Binding Post, GND	58474	DF21GC	BP-11G	3
---	Shorting Link for LO & GND Posts	24655	938-L	BP-6	3
J1218	Receptacle, Microphone, ANALOG OUTPUT	02660	80-PC2F	CS-32	3
---	Plug, mate of J1218 (Supplied)	02660	80-MC2M	CS-33	-
P1202	1 pin connector, mate to J501	80164	CS-185	CS-185	-

DIODES

Circuit Desig.	Type	Mfr. Code	Mfr. Part No.	Keithley Part No.	Fig. Ref.
D1201	Silicon	01295	1N645	RF-14	28
D1202	Silicon	01295	1N645	RF-14	28
D1203	Silicon	01295	1N645	RF-14	28
D1204	Silicon	01295	1N645	RF-14	28
D1205	Silicon	01295	1N645	RF-14	28
D1206	Silicon	01295	1N645	RF-14	28
D1207	Silicon	01295	1N645	RF-14	28
D1208	Silicon	01295	1N645	RF-14	28
D1209	Silicon	01295	1N914	RF-28	28
D1210	Silicon	01295	1N645	RF-14	28
D1211	Silicon	02735	1N3255	RF-17	28
D1212	Silicon	02735	1N3255	RF-17	28
D1213	Silicon	02735	1N3255	RF-17	28
D1214	Zener	84970	VR47	DZ-30	28
D1215	Silicon	01295	1N645	RF-14	28
D1216	Silicon	01295	1N645	RF-14	28
D1217	Silicon	02735	1N3255	RF-17	28
D1218	Silicon	02735	1N3255	RF-17	28

LAMPS

Circuit Desig.	Description	Mfr. Code	Mfr. Part No.	Keithley Part No.	Fig. Ref.
D81201	Range Changing Pilot Light,	91802	2100 series	PL-46	2

MAIN CHASSIS (Cont'd)
RELAYS

Circuit Desig.	Description	Mfr. Code	Mfr. Part No.	Keithley Part No.	Fig. Ref.
K1201(A & B)	Reed Relay	27682	525-0002	RL-34	28
K1202 "	Reed Relay	27682	525-0002	RL-34	28
K1203 "	Reed Relay	27682	525-0002	RL-34	28
K1204 "	Reed Relay	27682	525-0002	RL-34	28
K1205 "	Reed Relay	27682	525-0002	RL-34	28
K1206 "	Reed Relay	27682	525-0002	RL-34	28
K1207 "	Reed Relay	27682	525-0002	RL-34	28
K1208 "	Reed Relay	27682	525-0002	RL-34	28

PRINTED CIRCUIT SUB-ASSEMBLIES

Circuit Desig.	Description	Keithley Part No.
23430B	Input FET P.C. Board, with components.	23730B
PC-207	Polarity P.C. Board, with components. less components.	PC-207 22875B
PC-208	Thousand P.C. Board, with components.	PC-208 22878B
PC-209	Output Buffer P.C. Board, Model 4401, with components. less components.	PC-209 22882B
PC-212	Range Counter/Decoder P.C. Board, with components. less components.	PC-212 22892B
PC-214	Range Control P.C. Board, with components. less components.	PC-214 22895B
PC-217	Oscillator P.C. Board, with components. less components.	PC-217 23061B
PC-218	Output Buffer P.C. Board, Model 4401, with components. less components.	PC-218 23065B
PC-219	Integrator P.C. Board, with components. less components.	PC-219 23068B
PC-229	Readout P.C. Board, with components. less components.	PC-229 23628C
PC-230	Tube & Driver P.C. Board, with components. less components.	PC-230 23633B

MAIN CHASSIS (Cont'd)
RESISTORS

Circuit Desig.	Value	Rating	Type	Mfr. Code	Mfr. Part No.	Keithley Part No.	Fig. Ref.
R1201	10 MΩ	1%, 1/2 W	DCb	91637	DCF-1/2	R12-10M	28
R1202	10 kΩ	20%, 2 W	WWVar	71450	INS 115	RP50-10K	28
R1203**	100 kΩ	10%, 1/4 W	Comp				
R1204	15 kΩ	1%, 1/8 W	MtF	07716	CEA	R88-15K	28
R1205	100 Ω	10%, 1/2 W	Comp	01121	EB	R1-100	28
R1206	18.2 kΩ	1%, 1/8 W	MtF	07716	CEA	R88-18.2K	28
R1207	500 Ω	±20%, 2 W	Cermet	71450	551	RP72-500	28
R1208	18.2 kΩ	1%, 1/8 W	MtF	07716	CEA	R88-18.2K	28
R1209	22 kΩ	10%, 1/4 W	Comp	44655	RC07	R76-22K	28
R1210	4.7 kΩ	10%, 1/4 W	Comp	44655	RC07	R76-4.7K	28
R1211	4.7 kΩ	10%, 1/4 W	Comp	44655	RC07	R76-4.7K	28
R1212	680 Ω	10%, 1/4 W	Comp	44655	RC07	R76-680	28
R1213	3.3 kΩ	10%, 1/2 W	Comp	01121	EB	R1-3.3K	28
R1214	100 Ω	10%, 2 W	Comp	01121	HB	R3-100	28
R1215	470 Ω	10%, 2 W	Comp	01121	HB	R3-470	28
R1216	100 Ω	10%, 1/2 W	Comp	01121	EB	R1-100	28
R1217	116.67 Ω	0.1%, 1 W	WW	01686	7040	R70-116.67	28
R1218	4.75 kΩ	1%, 1/2 W	MtF	07716	CEC	R94-4.75K	28
R1219	1.1667 kΩ	0.1%, 1 W	WW	01686	7040	R70-1.1667K	28
R1220	11.667 kΩ	0.1%, 1 W	WW	01686	7040	R70-11.667K	28
R1221	115 kΩ	1%, 1/2 W	MtF	07716	CEC	R94-115K	28
R1222	1.15 MΩ	1%, 1/2 W	MtF	07716	CEC	R94-1.15M	28
R1223	10 MΩ	1%, 1/2 W	DCb	91637	DCF-1/2	R12-10M	28
R1224	1.5 MΩ	1%, 1/2 W	DCb	91637	DCF-1/2	R12-1.5M	28
R1225	100 MΩ	1%, 2 W	DCb	91637	DC-2	R14-100M	28
R1226	15 MΩ	1%, 1 W	DCb	91637	DC-1	R13-15M	28
R1227	10 ⁹ Ω	+3-0%, 1/R W	Gcb	80164	23092A	23092A	28
R1228	4.75 kΩ	1%, 1/2 W	MtF	07716	CEC	R94-4.75K	28
R1229	250 kΩ	±20%, 2 W	Cermet	71450	550	RP79-250K	28
R1230	5 kΩ	20%, 2 W	WWVar	71450	INS 115	RP50-5K	28
R1231	50 kΩ	±20%, 2 W	Cermet	71450	550	RP74-50K	28
R1232	500 kΩ	±20%, 1/4 W	CbVar	71450	Type-45	RP73-500K	28
R1233	560 Ω	10%, 1/2 W	Comp	01121	EB	R1-560	28
R1234	1 kΩ	20%, 2 W	WWVar	71450	INS 115	RP50-1K	28
R1235	1 kΩ	20%, 2 W	WWVar	71450	INS 115	RP50-1K	28
R1236	249 kΩ	10%, 1/2 W	MtF	07716	CEC	R94-249K	28
R1237	500 kΩ	±20%, 1/4 W	CbVar	71450	GC45	RP75-500K	28
R1238	1 kΩ	20%, 2 W	WWVar	71450	INS 115	RP50-1K	28

SWITCHES AND CONTROLS

Circuit Desig.	Description	Mfr. Code	Keithley Part No.	Fig. Ref.
S1201	Rotary Switch, FILTER	80164	SW-280	2
---	Knob Assembly, Filter Switch	80164	20933A	
S1202	Toggle Switch, RANGE 10 ⁻² /DOWN	80164	SW-277	2
S1203	Toggle Switch, RANGE HOLD/AUTOMATIC	80164	SW-236	2
S1204	Toggle Switch, ZERO CHECK/OPERATE	80164	SW-236	2

** R1203 is part of FET Input Card

MAIN CHASSIS (Cont'd)
SWITCHES AND CONTROLS (Cont'd.)

Circuit Desig.	Description	Mfr. Code	Keithley Part No.	Fig. Ref.
S1205	Rotary Switch, DISPLAY RATE (see also R1237)	71450	RP75-500K	2
---	Knob Assembly, Display Rate Control	80164		2
---	Screwdriver Adjust potentiometer, ZERO ADJUST (R1207)	71450	RP50-10K	2

TRANSISTORS

Circuit Desig.	Mfr. Code	Mfr. Part No.	Keithley Part No.	Fig. Ref.
Q1201**	80164			28
Q1202**	80164			28
Q1203	07263	S17638	TG-33	28
Q1204	07263	S17638	TG-33	28
Q1205	04713	2N3904	TG-47	28
Q1206	71279	ES-5321	TG-54	28

**Transistors Q1201 and Q1202 are matched

POWER SUPPLY PARTS LIST
("100" Series, PG-221)

CAPACITORS

Circuit Desig.	Value	Rating	Type	Mfr. Code	Mfr. Part No.	Keithley Part No.	Fig. Ref.
C101	2000 μ F	15 V	EA1		36-750-2000-15C	C93-2000M	28
C102	100 pF	600 V	CerD	72982	ED-100	C22-100P	28
C103	150 pF	600 V	CerD	72982	ED-150	C22-150P	28
C104	200 μ F	35 V	EA1	90201	MTV200N35PDN	C177-200M	28
C105	200 μ F	35 V	EA1	90201	MTV200N35PDN	C177-200M	28
C106	200 μ F	35 V	EA1	90201	MTV200N35PDN	C177-200M	28
C107	200 μ F	35 V	EA1	90201	MTV200N35PDN	C177-200M	28
C108	1.2 μ F	20 V	ETT	17554	TSD1-20-125	C179-1.2M	28
C109	5 pF	600 V	CerD	72982	ED-5	C22-5P	28
C110	125 μ F	15 V	ETB	73445	C426	C3-125M	28
C111	125 μ F	15 V	ETB	73445	C426	C3-125M	28
C112	15 μ F	300 V	EA1	90201	PTC-015-N-300-P-3-E	C173-15M	28
C113	500 μ F	25 V	EA1	56289	89D234	C94-500M	28
C114	68 pF						

DIODES

Circuit Desig.	Type	Mfr. Code	Mfr. Part No.	Keithley Part No.	Fig. Ref.
D101	Silicon	13327	1N4139	RF-34	28
D102	Silicon	13327	1N4139	RF-34	28
D103	Silicon	01295	1N645	RF-14	28
D104	Silicon	01295	1N645	RF-14	28
D105	Silicon	01295	1N645	RF-14	28
D106	Silicon	01295	1N645	RF-14	28
D107	Silicon	01295	1N645	RF-14	28
D108	Silicon	01295	1N645	RF-14	28
D109	Silicon	01295	1N645	RF-14	28
D110	Zener	04713	1N936	DZ-5	28

POWER SUPPLY (Cont'd)
DIODES (Cont'd.)

Circuit Desig.	Type	Mfr. Code	Mfr. Part No.	Keithley Part No.	Fig. Ref.
D111	Silicon	02735	1N3255	RF-17	28
D112	Silicon	01295	1N645	RF-14	28
D113	Silicon	01295	1N645	RF-14	28

MISCELLANEOUS PARTS

Circuit Desig.	Description	Mfr. Code	Mfr. Part No.	Keithley Part No.	Fig. Ref.
F101 (117V)	Fuse, slow blow, 3/8 A	71400	Type MDL	FU-18	3
F101 (234V)	Fuse, quick acting, 200mA	75915	361.200	FU-24	3
---	Fuse Holder	75915	342012	FH-3	-
P101	Cord Set, 6 feet	93656	4638-13	CO-5	3
S101	Slide Switch, 117-234V	80164	SW-151	SW-151	3
S102	Toggle Switch, POWER	80164	SW-265	SW-265	2
T101	Power Transformer	80164	TR-114	TR-114	19

RESISTORS

Circuit Desig.	Value	Rating	Type	Mfr. Code	Mfr. Part No.	Keithley Part No.	Fig. Ref.
R101	6.8 k Ω	10%, 1/4 W	Comp	44655	RC07	R76-6.8K	28
R102	0.2 Ω	\pm 10%, 4.25W	TCu	91637	CW-2	R151-0.2	28
R103	10 k Ω	1%, 1/8 W	MtF	07716	CEA	R88-10K	28
R104	1.1 k Ω	1%, 1/8 W	MtF	07716	CEA	R88-1.1K	28
R105	1 k Ω	10%, 1/4 W	Comp	44655	RC07	R76-1K	28
R106	100 Ω	1%, 1/8 W	MtF	07716	CEA	R88-100	28
R107	150 Ω	1%, 1/8 W	MtF	07716	CEA	R88-150	28
R108	33 k Ω	10%, 1/4 W	Comp	44655	RC07	R76-33K	28
R109	3 Ω	1%, 1/2 W	DCb	91637	DCF-1/2	R12-3	28
R110	680 Ω	10%, 1/4 W	Comp	44655	RC07	R76-680	28
R111	3.3 k Ω	10%, 1/4 W	Comp	44655	RC07	R76-3.3K	28
R112	4.7 k Ω	10%, 1/4 W	Comp	44655	RC07	R76-4.7K	28
R113	3.3 k Ω	10%, 1/4 W	Comp	44655	RC07	R76-3.3K	28
R114	4.75 k Ω	1%, 1/8 W	MtF	07716	CEA	R88-4.75K	28
R115	2 k Ω	20%, 2 W	WWVar	71450	INS 115	RP50-2K	28
R116	8.06 k Ω	1%, 1/8 W	MtF	07716	CEA	R88-8.06K	28
R117	15 k Ω	10%, 1/4 W	Comp	44655	RC07	R76-15K	28
R118	7.5 k Ω	1%, 1/8 W	MtF	07716	CEA	R88-7.5K	28
R119	33 k Ω	10%, 1/4 W	Comp	44655	RC07	R76-33K	28
R120	3 Ω	1%, 1/2 W	DCb	91637	DCF-1/2	R12-3	28
R121	33 k Ω	10%, 1/4 W	Comp	44655	RC07	R76-33K	28
R122	33 k Ω	10%, 1/4 W	Comp	44655	RC07	R76-33K	28
R123	7.32 k Ω	1%, 1/8 W	MtF	07716	CEA	R88-7.32K	28
R124	82 Ω	10%, 1/2 W	Comp	01121	EB	R1-82	28
R125	1 M Ω	10%, 1/4 W	Comp	44655	RC07	R76-1M	28
R126	100 k Ω	10%, 1/4 W	Comp	44655	RC07	R76-100K	28
R127	56 k Ω	10%, 1/4 W	Comp	44655	RC07	R76-56K	28
R128	80.6 k Ω	1%, 1/2 W	MtF	07716	CEC	R94-80.6K	28

POWER SUPPLY (Cont'd)
RESISTORS (Cont'd.)

Circuit Desig.	Value	Rating	Type	Mfr. Code	Mfr. Part No.	Keithley Part No.	Fig. Ref.
R129	7.32 k Ω	1%, 1/8 W	MEF	07716	CEA	R88-7.32K	28
R130	1.5 k Ω	10%, 1/4 W	Comp	44655	RC07	R76-1.5K	28
R131	1 k Ω	10%, 1/4 W	Comp	44655	RC07	R76-1K	28
R132	12 k Ω	10%, 1/4 W	Comp	44655	RC07	R76-12K	28
R133	10 k Ω	10%, 1/4 W	Comp	44655	RC07	R76-10K	28

TRANSISTORS

Circuit Desig.	Mfr. Code	Mfr. Part No.	Keithley Part No.	Fig. Ref.
Q101	02735	2N5183	TG-68	28
Q102	71279	ES-5321	TG-54	28
Q103	07263	2N3565	TG-39	28
Q104	07263	2N3565	TG-39	28
Q105	07263	S17638	TG-33	28
Q106	07263	2N3565	TG-39	28
Q107	02734	40317	TG-43	28
Q108	07263	2N3565	TG-39	28
Q109	07263	2N3565	TG-39	28
Q110	07263	S17638	TG-33	28
Q111	02734	40319	TG-50	28
Q112	07263	S17638	TG-33	28
Q113	07263	S17638	TG-33	28
Q114	07263	2N3565	TG-39	28
Q115	07263	2N3565	TG-39	28
Q116	07263	S17638	TG-33	28
Q117	07263	S17638	TG-33	28
Q118	02735	40346	TG-44	28
Q119	02735	40346	TG-44	28
Q120	07263	2N3565	TG-39	28

POLARITY BOARD PARTS LIST
("200" Series, PC-207)

CAPACITORS

Circuit Desig.	Value	Rating	Type	Mfr. Code	Mfr. Part No.	Keithley Part No.	Fig. Ref.
C201	150 pF	600 V	CerD	72982	ED-150	C22-150P	20

INTEGRATED CIRCUITS

Circuit Desig.	Description	Mfr. Code	Mfr. Part No.	Keithley Part No.	Fig. Ref.
QA201	Dual J-K Flip-Flop	04713	MC790P	IC-8	20
QA202	Quad 2 Input Gate	04713	MC724P	IC-5	20
QA203	Quad 2 Input Gate	04713	MC724P	IC-5	20
QA204	Quad 2 Input Gate	04713	MC724P	IC-5	20
QA205	Quad 2 Input Gate	04713	MC724P	IC-5	20
QA206	Dual J-K Flip-Flop	04713	MC790P	IC-8	20
QA207	Dual 3 Input Buffer, non-inverting	04713	MC788P	IC-6	20

POLARITY BOARD (Cont'd)

LAMPS

Circuit Desig.	Description	Mfr. Code	Mfr. Part No.	Keithley Part No.	Fig. Ref.
DS201	±Polarity Pilot Light	91802	2330 Series	PL-43	20

RESISTORS

Circuit Desig.	Value	Rating	Type	Mfr. Code	Mfr. Part No.	Keithley Part No.	Fig. Ref.
R201	270 Ω	10%, 1/4 W	Comp	44655	RC07	R76-270	20
R202	2.2 k Ω	10%, 1/4 W	Comp	44655	RC07	R76-2.2K	20
R203	1.5 k Ω	10%, 1/4 W	Comp	44655	RC07	R76-1.5K	20
R204	1.5 k Ω	10%, 1/4 W	Comp	44655	RC07	R76-1.5K	20

TRANSISTORS

Circuit Desig.	Mfr. Code	Mfr. Part No.	Keithley Part No.	Fig. Ref.
Q201	02735	2N5184	TG-67	20
Q202	02735	2N5184	TG-67	20

THOUSAND BOARD PARTS LIST
("300" Series, PC-208)

INTEGRATED CIRCUITS

Circuit Desig.	Description	Mfr. Code	Mfr. Part No.	Keithley Part No.	Fig. Ref.
QA301	Dual J-K Flip-Flop	04713	MC790P	IC-8	21
QA302	Dual J-K Flip-Flop	04713	MC790P	IC-8	21
QA303	Quad 2 positive logic Nor Input Gate	04713	MC724P	IC-5	21
QA304	Hex Inverter	04713	MC789P	IC-7	21

LAMPS

Circuit Desig.	Description	Mfr. Code	Mfr. Part No.	Keithley Part No.	Fig. Ref.
DS301	Pilot Light, front panel thousands tube	80164	PL-42	PL-42	21

RESISTORS

Circuit Desig.	Value	Rating	Type	Mfr. Code	Mfr. Part No.	Keithley Part No.	Fig. Ref.
R301	1.5 k Ω	10%, 1/4 W	Comp	44655	RC07	R76-1.5K	21
R302	100 k Ω	10%, 1 W	Comp	01121	GB	R2-100K	21

TRANSISTORS

Circuit Desig.	Mfr. Code	Mfr. Part No.	Keithley Part No.	Fig. Ref.
Q30	02735	2N5184	TG-67	21

READOUT BOARD PARTS LIST
("400" Series, PC-229)

CONNECTORS

Circuit Desig.	Description	Mfr. Code	Mfr. Part No.	Keithley Part No.	Fig. Ref.
P401	Plug, 6 pins, connects to J1206	73690	02-006-105-6-200	CS-223	29
P402	Plug, 22 pins, connects to J1207	73690	02-015-105-6-200	CS-222	29

INTEGRATED CIRCUITS

Circuit Desig.	Description	Mfr. Code	Mfr. Part No.	Keithley Part No.	Fig. Ref.
QA401	Dual J-K Flip-Flop	04713	MC791P	IC-9	29
QA402	Dual J-K Flip-Flop	04713	MC791P	IC-9	29
QA403	Dual J-K Flip-Flop	04713	MC791P	IC-9	29
QA404	Dual J-K Flip-Flop	04713	MC790P	IC-8	29
QA405	Dual J-K Flip-Flop	04713	MC790P	IC-8	29
QA406	Dual J-K Flip-Flop	04713	MC790P	IC-8	29
QA407	Quad 2 Input Gate	04713	MC724P	IC-5	29
QA408	Quad 2 Input Gate	04713	MC724P	IC-5	29
QA409	Dual J-K Flip-Flop	04713	MC790P	IC-8	29
QA410	Dual J-K Flip-Flop	04713	MC790P	IC-8	29
QA411	Dual J-K Flip-Flop	04713	MC790P	IC-8	29
QA412	Dual J-K Flip-Flop	04713	MC790P	IC-8	29
QA413	Dual J-K Flip-Flop	04713	MC790P	IC-8	29
QA414	Dual J-K Flip-Flop	04713	MC790P	IC-8	29
QA415	Decimal Decoder/Driver	07263	U6B996079X	IC-3	29
QA416	Decimal Decoder/Driver	07263	U6B996079X	IC-3	29
QA417	Decimal Decoder/Driver	07263	U6B996079X	IC-3	29

READOUT TUBES

Circuit Desig.	Description	Mfr. Code	Mfr. Part No.	Keithley Part No.	Fig. Ref.
V401	Units Readout Tube	80164	---	EV-841	29
V402	Tens Readout Tube	80164	---	EV-841	29
V403	Hundreds Readout Tube	80164	---	EV-841	29

RESISTORS

Circuit Desig.	Value	Rating	Type	Mfr. Code	Mfr. Part No.	Keithley Part No.	Fig. Ref.
R401	10 k Ω	5%, 1/2 W	Comp	01121	EB	R19-10K	29
R402	10 k Ω	5%, 1/2 W	Comp	01121	EB	R19-10K	29
R403	10 k Ω	5%, 1/2 W	Comp	01121	EB	R19-10K	29

OSCILLATOR BOARD PARTS LIST
("500" Series, PC-217)

CAPACITORS

Circuit Desig.	Value	Rating	Type	Mfr. Code	Mfr. Part No.	Keithley Part No.	Fig. Ref.
C501	.0022 μ F	100V	Poly	13934	E3FR-222-1-C	C152-.0022M	25
C502	.001 μ F	100V	Poly	13934	E3FR-222-1-C	C152-.001M	25
C503	4.5-25 pF	500V	Cer Trimmer	71590	822AZ	C76-4.5-25P	25
C504	22 pF	500V	Mica	84171	DM15-220J	C21-22P	25
C505	470 pF	600V	CerD	72982	ED-470	C22-470P	25

OSCILLATOR BOARD (Cont'd)
CAPACITORS (Cont'd.)

Circuit Desig.	Value	Rating	Type	Mfr. Code	Mfr. Part No.	Keithley Part No.	Fig. Ref.
C506	220 pF	600V	CerD	72982	ED-220	C22-220P	25
C507	4.7 μ F	20V	ETT	05397	K4R7J20K	C80-4.7M	25
C508	10 μ F	20V	ETT	17554	TSD2-20-106	C179-10M	25

MISCELLANEOUS PARTS

Circuit Desig.	Description	Mfr. Code	Mfr. Part No.	Keithley Part No.	Fig. Ref.
D501	Diode, Silicon, 1N645	01295	-	RF-14	25
D502	Diode, Silicon, 1N645	01295	-	RF-14	25
D503	Diode, Silicon, 1N914	01295	-	RF-28	25
J501	Varicon Contact	73690	02-001-113-6	CS-224	25
QA501	Quad 2 positive logic Nor Input Gate	04713	MC724P	IC-5	25
QA502	Quad 2 positive logic Nor Input Gate	04713	MC724P	IC-5	25
Y501**	Crystal, 60 Hz	80164	CR-1	CR-1	25
	Crystal, 50 Hz	80164	CR-2	CR-2	25

RESISTORS

Circuit Desig.	Value	Rating	Type	Mfr. Code	Mfr. Part No.	Keithley Part No.	Fig. Ref.
R501	3.3 k Ω	10%, 1/4 W	Comp	44655	RC07	R76-3.3K	25
R502	33 k Ω	10%, 1/4 W	Comp	44655	RC07	R76-33K	25
R503	68.1 Ω	1%, 1/8 W	MtF	07716	CEA	R88-68.1	25
R504	4.99 k Ω	1%, 1/8 W	MtF	07716	CEA	R88-4.99K	25
R505	1 k Ω	10%, 1/4 W	Comp	44655	RC07	R76-1K	25
R506	1 k Ω	10%, 1/4 W	Comp	44655	RC07	R76-1K	25
R507	1 k Ω	1%, 1/8 W	MtF	07716	CEA	R88-1K	25
R508	470 Ω	10%, 1/4 W	Comp	44655	RC07	R76-470	25
R509	4.7 k Ω	10%, 1/4 W	Comp	44655	RC07	R76-4.7K	25
R510	56 k Ω	10%, 1/4 W	Comp	44655	RC07	R76-56K	25
R511	4.7 k Ω	10%, 1/4 W	Comp	44655	RC07	R76-4.7K	25
R512	470 Ω	10%, 1/4 W	Comp	44655	RC07	R76-470	25
R513	680 Ω	10%, 1/4 W	Comp	44655	RC07	R76-680	25
R514	470 Ω	10%, 1/4 W	Comp	44655	RC07	R76-470	25
R515	237 Ω	1%, 1/8 W	MtF	07716	CEA	R88-237	25
R516	1 k Ω	1%, 1/8 W	MtF	07716	CEA	R88-1K	25
R517	4.99 k Ω	1%, 1/8 W	MtF	07716	CEA	R88-4.99K	25
R518	56 k Ω	10%, 1/4 W	Comp	44655	RC07	R76-56K	25
R519	237 Ω	1%, 1/8 W	MtF	07716	CEA	R88-237	25
R520	3.3 k Ω	10%, 1/4 W	Comp	44655	RC07	R76-3.3K	25
R521	6.8 k Ω	10%, 1/4 W	Comp	44655	RC07	R76-6.8K	25
R522	1.5 k Ω	10%, 1/4 W	Comp	44655	RC07	R76-1.5K	25
R523	1 k Ω	10%, 1/4 W	Comp	44655	RC07	R76-1K	25
R524	1 k Ω	10%, 1/4 W	Comp	44655	RC07	R76-1K	25
R525	10 k Ω	10%, 1/4 W	Comp	44655	RC07	R76-10K	25
R526	1 k Ω	10%, 1/4 W	Comp	44655	RC07	R76-1K	25
R527	3.9 k Ω	10%, 1/4 W	Comp	44655	RC07	R76-3.9K	25
R528	3.9 k Ω	10%, 1/4 W	Comp	44655	RC07	R76-3.9K	25
R529	330 Ω	10%, 1/4 W	Comp	44655	RC07	R76-330	25
R530	1.5 k Ω	10%, 1/4 W	Comp	44655	RC07	R76-1.5K	25

OSCILLATOR BOARD (Cont'd)
RESISTORS (Cont'd.)

Circuit Desig.	Value	Rating	Type	Mfr. Code	Mfr. Part No.	Keithley Part No.	Fig. Ref.
R531	5.6 k Ω	10%, 1/4 W	Comp	44655	RC07	R76-5.6K	25
R532	4.7 k Ω	10%, 1/4 W	Comp	44655	RC07	R76-4.7K	25
R533	10 Ω	10%, 1/4 W	Comp	44655	RC07	R76-10	25
R534	1.5 k Ω	10%, 1/4 W	Comp	44655	RC07	R76-1.5K	25
R535	1 k Ω	1%, 1/8 W	MtF	07716	CEA	R88-1K	25
R536	47 Ω	10%, 1/4 W	Comp	44655	RC07	R76-47	25
R537	33 Ω	10%, 1/4 W	Comp	44655	RC07	R76-33	25
R538	4.02 k Ω	1%, 1/8 W	MtF	07716	CEA	R88-4.02K	25

TRANSISTORS

Circuit Desig.	Mfr. Code	Mfr. Part No.	Keithley Part No.	Fig. Ref.
Q501	07263	2N5134	TG-65	25
Q502	07263	2N5134	TG-65	25
Q503	07263	2N5134	TG-65	25
Q504	07263	2N5134	TG-66	25
Q505	07263	2N5134	TG-65	25
Q506	07263	2N5139	TG-66	25
Q507	07263	2N5134	TG-65	25
Q508	07263	2N5139	TG-66	25
Q509	07263	2N5134	TG-65	25
Q510	07263	2N5134	TG-65	25
Q511	07263	2N5134	TG-65	25
Q512	07263	2N5134	TG-65	25
Q513	07263	2N5134	TG-65	25
Q514	03508	2N2646	TG-52	25

INTEGRATOR BOARD PARTS LIST
("600" Series, PC-219)
CAPACITORS

Circuit Desig.	Value	Rating	Type	Mfr. Code	Mfr. Part No.	Keithley Part No.	Fig. Ref.
C601	100 pF	600V	CerD	72982	ED-100	C22-100P	27
C602	10 pF	500V	Poly	71590	CPR-10J	C138-10P	27
C603	0.082 μ F	100V	Poly	13934	E3FR-222-1-C	C152-.082M	27
C604	10 μ F	20V	ETT	17554	TSD2-20-106	C179-10M	27
C605	220 pF	600V	CerD	72982	ED-220	C22-220P	27
C606	220 pF	600V	CerD	72982	ED-220	C22-220P	27
C607	.0047 μ F	600V	CerD	72982	ED-.0047	C22-.0047M	27
C608	0.1 μ F	250V		73445	C280AE/P100K	C178-.1M	27
C609	10 μ F	20V	ETT	17554	TSD2-20-106	C179-10M	27
C610	22 pF	1000V	CerD	56289	56AQ22	C72-22P	27
C611	0.1 μ F	250V		73445	C280AE/P100K	C178.1M	27
C612	10 μ F	20V	ETT	17554	TSD2-20-106	C179-10M	27
C613	10 μ F	20V	ETT	17554	TSD2-20-106	C179-10M	27
C614	22 μ F	10V	ETT	17554	TSD2-10-226	C180-22M	27

INTEGRATOR BOARD (Cont'd)
DIODES

Circuit Desig.	Type	Mfr. Code	Mfr. Part No.	Keithley Part No.	Fig. Ref.
D601	Zener	04713	1N936	DZ-5	27
D602	Zener	04713	1N936	DZ-5	27
D603	Silicon	07263	2N3565	TG-39	27
D604	Silicon	07263	2N3565	TG-39	27
D605	Silicon	01295	1N645	RF-14	27
D606	Silicon	01295	1N645	RF-14	27
D607	Silicon	01295	1N914	RF-28	27
D608	Silicon	01295	1N914	RF-28	27
D609	Silicon	01295	1N645	RF-14	27
D610	Silicon	01295	1N645	RF-14	27
D611	Silicon	01295	1N645	RF-14	27
D612	Silicon	01295	1N645	RF-14	27
D613	Silicon	01295	1N914	RF-28	27
D614	Silicon	01295	1N914	RF-28	27
D615	Silicon	01295	1N645	RF-14	27

INTEGRATED CIRCUITS

Circuit Desig.	Description	Mfr. Code	Mfr. Part No.	Keithley Part No.	Fig. Ref.
QA601	Integrated Circuit	12040	LM-201	IC-2	27
QA602	Integrated Circuit	12040	LM-201	IC-2	27
QA603	High Speed Differential Comparator	07263	65B771039X	IC-4	27
QA604	Quad 2 Input Gate	04713	MC724P	IC-5	27

RESISTORS

Circuit Desig.	Value	Rating	Type	Mfr. Code	Mfr. Part No.	Keithley Part No.	Fig. Ref.
R601	10 k Ω	10%, 1/4 W	Comp	44655	RC07	R76-10K	27
R602	*	1%, 1/8 W	MtF	07716	CEA	R88-*	27
R603	7.5 k Ω	1%, 1/8 W	MtF	07716	CEA	R88-7.5K	27
R604	7.5 k Ω	1%, 1/8 W	MtF	07716	CEA	R88-7.5K	27
R605	7.5 k Ω	1%, 1/8 W	MtF	07716	CEA	R88-7.5K	27
R606	10 k Ω	\pm 20%, 3/4 W	Cermet	73138	77PR10K	RP64-10K	27
R607	*	1%, 1/8 W	MtF	07716	CEA	R88-*	27
R608	7.5 k Ω	1%, 1/8 W	MtF	07716	CEA	R88-7.5K	27
R609	7.5 k Ω	1%, 1/8 W	MtF	07716	CEA	R88-7.5K	27
R610	7.5 k Ω	1%, 1/8 W	MtF	07716	CEA	R88-7.5K	27
R611	10 k Ω	\pm 20%, 3/4 W	Cermet	73138	77PR10K	RP64-10K	27
R612	10 k Ω	10%, 1/4 W	Comp	44655	RC07	R76-10K	27
R613	Not Used						
R614	499 Ω	1%, 1/8 W	MtF	07716	CEA	R88-499	27
R615	49.9 k Ω	1%, 1/8 W	MtF	07716	CEA	R88-49.9K	27
R616	680 Ω	10%, 1/4 W	Comp	44655	RC07	R76-680	27
R617	680 Ω	10%, 1/4 W	Comp	44655	RC07	R76-680	27
R618	33 k Ω	10%, 1/4 W	Comp	44655	RC07	R76-33K	27
R619	4.7 k Ω	10%, 1/4 W	Comp	44655	RC07	R76-4.7K	27
R620	33 k Ω	10%, 1/4 W	Comp	44655	RC07	R76-33K	27
R621	4.7 k Ω	10%, 1/4 W	Comp	44655	RC07	R76-4.7K	27
R622	4.7 k Ω	10%, 1/4 W	Comp	44655	RC07	R76-4.7K	27
R623	4.7 k Ω	10%, 1/4 W	Comp	44655	RC07	R76-4.7K	27
R624	49.9 k Ω	1%, 1/8 W	MtF	07716	CEA	R88-49.9K	27
R625	100 k Ω	10%, 1/4 W	Comp	44655	RC07	R76-100K	27

* Nominal value, factory selected.

INTEGRATOR BOARD (Cont'd)
RESISTORS (Cont'd.)

Circuit Desig.	Value	Rating	Type	Mfr. Code	Mfr. Part No.	Keithley Part No.	Fig. Ref.
R626	237 Ω	1%, 1/8 W	MtF	07716	CEA	R88-237	27
R627	301 k Ω	1%, 1/8 W	MtF	07716	CEA	R88-301K	27
R628	47 Ω	10%, 1/4 W	Comp	44655	RC07	R76-47	27
R629	100 k Ω	10%, 1/4 W	Comp	44655	RC07	R76-100K	27
R630	158 Ω	1%, 1/8 W	MtF	07716	CEA	R88-158	27
R631	158 Ω	1%, 1/8 W	MtF	07716	CEA	R88-158	27
R632	200 Ω	\pm 20%, 3/4 W	Cermet	73138	77PR200	RP64-200	27
R633	301 k Ω	1%, 1/8 W	MtF	07716	CEA	R88-301K	27
R634	1.5 k Ω	10%, 1/4 W	Comp	44655	RC07	R76-1.5K	27
R635	47 Ω	10%, 1/4 W	Comp	44655	RC07	R76-47	27
R636	2.2 k Ω	10%, 1/4 W	Comp	44655	RC07	R76-2.2K	27
R637	47 Ω	10%, 1/4 W	Comp	44655	RC07	R76-47	27
R638	47 Ω	10%, 1/4 W	Comp	44655	RC07	R76-47	27
R639	1.5 k Ω	10%, 1/4 W	Comp	44655	RC07	R76-1.5K	27
R640	1.5 k Ω	10%, 1/4 W	Comp	44655	RC07	R76-1.5K	27
R641	100 Ω	10%, 1/4 W	Comp	44655	RC07	R76-100	27
R642	10 Ω	10%, 1/4 W	Comp	44655	RC07	R76-10	27
R643	3.01 k Ω	1%, 1/8 W	MtF	07716	CEA	R88-3.01K	27
R644	1 k Ω	1%, 1/8 W	MtF	07716	CEA	R88-1K	27
R645	5.6 k Ω	10%, 1/4 W	Comp	44655	RC07	R76-5.6K	27
R646	5.6 k Ω	10%, 1/4 W	Comp	44655	RC07	R76-5.6K	27
R647	10 Ω	10%, 1/4 W	Comp	44655	RC07	R76-10	27
R648	402 Ω	1%, 1/8 W	MtF	07716	CEA	R88-402	27
R649	200 Ω	\pm 20%, 3/4 W	Cermet	73138	77PR200	RP64-200	27
R650	402 Ω	1%, 1/8 W	MtF	07716	CEA	R88-402	27
R651	3.3 k Ω	10%, 1/4 W	Comp	44655	RC07	R76-3.3K	27
R652	820 Ω	10%, 1/4 W	Comp	44655	RC07	R76-820	27
R653	2.2 k Ω	10%, 1/4 W	Comp	44655	RC07	R76-2.2K	27
R654	220 Ω	10%, 1/4 W	Comp	44655	RC07	R76-220	27
R655	10 k Ω	10%, 1/4 W	Comp	44655	RC07	R76-10K	27
R656	6.98 k Ω	1%, 1/8 W	MtF	44655	RC07	R88-6.98K	27
R657	6.04 k Ω	1%, 1/8 W	MtF	44655	RC07	R88-6.04K	27

TRANSISTORS

Circuit Desig.	Mfr. Code	Mfr. Part No.	Keithley Part No.	Fig. Ref.
Q601	07263	2N5139	TG-66	27
Q602	07263	2N5139	TG-66	27
Q603	07263	2N5134	TG-65	27
Q604	07263	2N5134	TG-65	27
Q605	04713	2N4220	TG-42	27
Q606	04713	2N4220	TG-42	27
Q607	01295	SF5043	TG-40	27
Q608	01295	SF5043	TG-40	27
Q609	07263	S17638	TG-33	27

RANGE CONTROL BOARD PARTS LIST
("700" Series, PC-214)

CAPACITORS

Circuit Desig.	Value	Rating	Type	Mfr. Code	Mfr. Part No.	Keithley Part No.	Fig. Ref.
C701	.001 μ F	600V	CerD	72982	ED-.001	C22-.001M	24
C702	.001 μ F	600V	CerD	72982	ED-.001	C22-.001M	24
C703	.0047 μ F	600V	CerD	72982	ED-.0047	C22-.0047M	24
C704	.001 μ F	600V	CerD	72982	ED-.001	C22-.001M	24
C705	.001 μ F	600V	CerD	72982	ED-.001	C22-.001M	24
C706	2.2 μ F	20V	ETT	17554	TSD1-20-225	C179-2.2M	24
C707	.001 μ F	600V	CerD	72982	ED-.001	C22-.001M	24

INTEGRATED CIRCUITS

Circuit Desig.	Description	Mfr. Code	Mfr. Part No.	Keithley Part No.	Fig. Ref.
QA701	Hex Inverter	04713	MC789P	IC-7	24
QA702	Quad 2 Input Gate	04713	MC724P	IC-5	24
QA703	Hex Inverter	04713	MC789P	IC-7	24
QA704	Triple 3 Input Gate	04713	MC792P	IC-10	24
QA705	Quad 2 Input Gate	04713	MC789P	IC-5	24
QA706	Quad 2 Input Gate	04713	MC789P	IC-5	24
QA707	Dual J-K Flip-Flop	04713	MC790P	IC-8	24
QA708	Hex Inverter	04713	MC789P	IC-7	24

MISCELLANEOUS PARTS

Circuit Desig.	Description	Mfr. Code	Mfr. Part No.	Keithley Part No.	Fig. Ref.
D701	Diode, Silicon	01295	1N914	RF-28	24
Q701	Transistor, Silicon	02735	2N5184	TG-67	24

RESISTORS

Circuit Desig.	Value	Rating	Type	Mfr. Code	Mfr. Part No.	Keithley Part No.	Fig. Ref.
R701	1 k Ω	10%, 1/4 W	Comp	44655	RC07	R76-1K	24
R702	2.7 k Ω	10%, 1/4 W	Comp	44655	RC07	R76-2.7K	24
R703	1.5 k Ω	10%, 1/4 W	Comp	44655	RC07	R76-1.5K	24
R704	2.7 k Ω	10%, 1/4 W	Comp	44655	RC07	R76-2.7K	24
R705	2.7 k Ω	10%, 1/4 W	Comp	44655	RC07	R76-2.7K	24
R706	1 k Ω	10%, 1/4 W	Comp	44655	RC07	R76-1K	24
R707	2.7 k Ω	10%, 1/4 W	Comp	44655	RC07	R76-2.7K	24
R708	560 Ω	10%, 1/4 W	Comp	44655	RC07	R76-560	24

RANGE COUNTER/DECODER BOARD PARTS LIST
("800" Series, PC-212)

INTEGRATED CIRCUITS

Circuit Desig.	Description	Mfr. Code	Mfr. Part No.	Keithley Part No.	Fig. Ref.
QA801	Dual J-K Flip-Flop	04713	MC791P	IC-9	23
QA802	Dual J-K Flip-Flop	04713	MC791P	IC-9	23
QA803	Quad 2 Input Gate	04713	MC724P	IC-5	23

RANGE COUNTER/DECODER BOARD (Cont'd)
INTEGRATED CIRCUITS (Cont'd.)

Circuit Desig.	Description	Mfr. Code	Mfr. Part No.	Keithley Part No.	Fig. Ref.
QA804	Triple 3 Input Gate	04713	MC792P	IC-10	23
QA805	Triple 3 Input Gate	04713	MC792P	IC-10	23
QA806	Dual 4 Input Gate	04713	MC725P	IC-11	23
QA807	Dual 4 Input Gate	04713	MC725P	IC-11	23
QA808	Hex Inverter	04713	MC789P	IC-7	23
QA809	Dual J-K Flip-Flop	04713	MC790P	IC-8	23
QA810	Dual J-K Flip-Flop	04713	MC790P	IC-8	23

TUBE & DRIVER BOARD PARTS LIST
("900" Series, PC-230)

CAPACITORS

Circuit Desig.	Value	Rating	Type	Mfr. Code	Mfr. Part No.	Keithley Part No.	Fig. Ref.
C901	2.2 μ F	20V	ETT	17554	TSD1-20-225	C179-2.2 μ F	30
C902	1.2 μ F	20V	ETT	17554	TSD1-20-125	C179-1.2 μ F	30
C903	1.2 μ F	20V	ETT	17554	TSD1-20-125	C179-1.2 μ F	30
C904	1.2 μ F	20V	ETT	17554	TSD1-20-125	C179-1.2 μ F	30
C905	1.2 μ F	20V	ETT	17554	TSD1-20-125	C179-1.2 μ F	30
C906	1.2 μ F	20V	ETT	17554	TSD1-20-125	C179-1.2 μ F	30

CONNECTORS

Circuit Desig.	Description	Mfr. Code	Mfr. Part No.	Keithley Part No.	Fig. Ref.
J901	Contact Pin	80164	TE-69	TE-69	30
J902	Contact Pin	80164	TE-69	TE-69	30
J903	Contact Pin	80164	TE-69	TE-69	30
J904	Contact Pin	80164	TE-69	TE-69	30
J905	Contact Pin	80164	TE-69	TE-69	30
J906	Contact Pin	80164	TE-69	TE-69	30
J907	Contact Pin	80164	TE-69	TE-69	30
J908	Contact Pin	80164	TE-69	TE-69	30
J909	Contact Pin	80164	TE-69	TE-69	30

INTEGRATED CIRCUITS

Circuit Desig.	Description	Mfr. Code	Mfr. Part No.	Keithley Part No.	Fig. Ref.
QA901	Quad 2 Input Gate	04713	MC724P	IC-5	30
QA902	Quad 2 Input Gate	04713	MC724P	IC-5	30
QA903	Quad 2 Input Gate	04713	MC724P	IC-5	30

READOUT TUBES

Circuit Desig.	Description	Mfr. Code	Mfr. Part No.	Keithley Part No.	Fig. Ref.
V901	Range Readout Tube	80164	---	EV-841	30

TUBE & DRIVER BOARD (Cont'd)
RESISTORS

Circuit Desig.	Value	Rating	Type	Mfr. Code	Mfr. Part No.	Keithley Part No.	Fig. Ref.
R901	820 Ω	10%, 1/4 W	Comp	44655	RC07	R76-820	30
R902	820 Ω	10%, 1/4 W	Comp	44655	RC07	R76-820	30
R903	820 Ω	10%, 1/4 W	Comp	44655	RC07	R76-820	30
R904	820 Ω	10%, 1/4 W	Comp	44655	RC07	R76-820	30
R905	820 Ω	10%, 1/4 W	Comp	44655	RC07	R76-820	30
R906	820 Ω	10%, 1/4 W	Comp	44655	RC07	R76-820	30
R907	820 Ω	10%, 1/4 W	Comp	44655	RC07	R76-820	30
R908	820 Ω	10%, 1/4 W	Comp	44655	RC07	R76-820	30
R909	22 k Ω	5%, 1/2 W	Comp	01121	EB	R19-22K	30
R910	820 Ω	10%, 1/4 W	Comp	44655	RC07	R76-820	30
R911	820 Ω	10%, 1/4 W	Comp	44655	RC07	R76-820	30
R912	820 Ω	10%, 1/4 W	Comp	44655	RC07	R76-820	30
R913	820 Ω	10%, 1/4 W	Comp	44655	RC07	R76-820	30
R914	820 Ω	10%, 1/4 W	Comp	44655	RC07	R76-820	30
R915	820 Ω	10%, 1/4 W	Comp	44655	RC07	R76-820	30
R916	820 Ω	10%, 1/4 W	Comp	44655	RC07	R76-820	30
R917	560 Ω	10%, 1/4 W	Comp	44655	RC07	R76-560	30
R918	1 k Ω	10%, 1/4 W	Comp	44655	RC07	R76-1K	30
R919	1.5 k Ω	10%, 1/4 W	Comp	44655	RC07	R76-1.5K	30
R920	1.5 k Ω	10%, 1/4 W	Comp	44655	RC07	R76-1.5K	30
R921	1.5 k Ω	10%, 1/4 W	Comp	44655	RC07	R76-1.5K	30
R922	1.5 k Ω	10%, 1/4 W	Comp	44655	RC07	R76-1.5K	30
R923	1.5 k Ω	10%, 1/4 W	Comp	44655	RC07	R76-1.5K	30
R924	560 Ω	10%, 1/4 W	Comp	44655	RC07	R76-560	30

TRANSISTORS

Circuit Desig.	Mfr. Code	Mfr. Part No.	Keithley Part No.	Fig. Ref.
Q901	02735	2N5184	TG-67	30
Q902	02735	2N5184	TG-67	30
Q903	02735	2N5184	TG-67	30
Q904	02735	2N5184	TG-67	30
Q905	02735	2N5184	TG-67	30
Q906	02735	2N5184	TG-67	30
Q907	02735	2N5184	TG-67	30
Q908	02735	2N5184	TG-67	30
Q909	04713	2N3904	TG-47	30
Q910	04713	2N3904	TG-47	30
Q911	04713	2N3904	TG-47	30
Q912	04713	2N3904	TG-47	30
Q913	04713	2N3904	TG-47	30
Q914	04713	2N3904	TG-47	30
Q915	04713	2N3904	TG-47	30
Q916	04713	2N3904	TG-47	30

MODEL 4401 OUTPUT BUFFER BOARD PARTS LIST
("1000" Series, PC-218)

NOTE

On schematic diagram 23457D there are 15 buffers labeled 'A' through 'P' not including 'I'. Each buffer is composed of 4 resistors and 3 transistors. A sample buffer circuit is given in the lower left hand corner of the schematic. Following is a sample replaceable parts list for each buffer.

BUFFER RESISTORS (A thru P)

Circuit Desig.	Value	Rating	Type	Mfr. Code	Mfr. Part No.	Keithley Part No.	Fig. Ref.
R1001	180 kΩ	10%, 1/4 W	Comp	44655	RC07	R76-180K	26
R1002	3.9 kΩ	10%, 1/4 W	Comp	44655	RC07	R76-3.9K	26
R1003	120 kΩ	10%, 1/4 W	Comp	44655	RC07	R76-120K	26
R1004	10 kΩ	10%, 1/4 W	Comp	44655	RC07	R76-10K	26

BUFFER TRANSISTORS (A thru P)

Circuit Desig.	Mfr. Code	Mfr. Part No.	Keithley Part No.	Fig. Ref.
Q1001	07263	2N3565	TG-39	26
Q1002	07263	2N3565	TG-39	26
Q1003	07263	2N3565	TG-39	26

MODEL 4401 OUTPUT BUFFER BOARD PARTS LIST
("1100" Series, PC-209)

CAPACITORS

Circuit Desig.	Value	Rating	Type	Mfr. Code	Mfr. Part No.	Keithley Part No.	Fig. Ref.
C1101	.001 μF	600V	CerD	72982	ED-.001	C22-.001M	22
C1102	.0033 μF	600V	CerD	72982	ED-.0033	C22-.0033M	22
C1103	.001 μF	600V	CerD	72982	ED-.001	C22-.001M	22
C1104	0.1 μF	250V		73445	C280AE/P100K	C178-0.1M	22
C1105	100 pF	600V	CerD	72982	ED-100	C22-100P	22
C1106	100 pF	600V	CerD	72982	ED-100	C22-100P	22
C1107	470 pF	600V	CerD	72982	ED-470	C22-470P	22
C1108	470 pF	600V	CerD	72982	ED-470	C22-470P	22
C1109	22 μF	10V	ETT	17554	TSD2-10-226	C180-22M	22
C1110	10 μF	20V	ETT	17554	TSD2-20-106	C179-10M	22

INTEGRATED CIRCUITS

Circuit Desig.	Description	Mfr. Code	Mfr. Part No.	Keithley Part No.	Fig. Ref.
QA1101	Quad 2 Input Gate	04713	MC724P	IC-5	22
QA1102	Quad 2 Input Gate	04713	MC724P	IC-5	22

RESISTORS

Circuit Desig.	Value	Rating	Type	Mfr. Code	Mfr. Part No.	Keithley Part No.	Fig. Ref.
R1101	1 kΩ	10%, 1/4 W	Comp	44655	RC07	R76-1K	22
R1102	3.3 kΩ	10%, 1/4 W	Comp	44655	RC07	R76-3.3K	22
R1103	1 kΩ	10%, 1/4 W	Comp	44655	RC07	R76-1K	22
R1104	3.3 kΩ	10%, 1/4 W	Comp	44655	RC07	R76-3.3K	22
R1105	120 kΩ	10%, 1/4 W	Comp	44655	RC07	R76-120K	22
R1106	10 kΩ	10%, 1/4 W	Comp	44655	RC07	R76-10K	22
R1107	180 kΩ	10%, 1/4 W	Comp	44655	RC07	R76-180K	22
R1108	2.2 kΩ	10%, 1/4 W	Comp	44655	RC07	R76-2.2K	22
R1109	1 kΩ	10%, 1/4 W	Comp	44655	RC07	R76-1K	22
R1110	10 kΩ	10%, 1/4 W	Comp	44655	RC07	R76-10K	22
R1111	120 kΩ	10%, 1/4 W	Comp	44655	RC07	R76-120K	22
R1112	180 kΩ	10%, 1/4 W	Comp	44655	RC07	R76-180K	22
R1113	2.2 kΩ	10%, 1/4 W	Comp	44655	RC07	R76-2.2K	22

RESISTORS (Cont'd.)

Circuit Desig.	Value	Rating	Type	Mfr. Code	Mfr. Part No.	Keithley Part No.	Fig. Ref.
R1114	6.98 k Ω	1%, 1/8 W	MtF	07716	CEA	R88-6.98K	22
R1115	6.04 k Ω	1%, 1/8 W	MtF	07716	CEA	R88-6.04K	22
R1116	2 k Ω	1%, 1/8 W	MtF	07716	CEA	R88-2K	22
R1117	120 k Ω	10%, 1/4 W	Comp	44655	RC07	R76-120K	22
R1118	10 k Ω	10%, 1/4 W	Comp	44655	RC07	R76-10K	22
R1119	180 k Ω	10%, 1/4 W	Comp	44655	RC07	R76-180K	22
R1120	3.9 k Ω	10%, 1/4 W	Comp	44655	RC07	R76-3.9K	22

TRANSISTORS

Circuit Desig.	Mfr. Code	Mfr. Part No.	Keithley Part No.	Fig. Ref.
Q1101	07263	2N3565	TG-39	22
Q1102	07263	2N3565	TG-39	22
Q1103	Not Used			
Q1104	07263	2N3565	TG-39	22
Q1105	07263	2N3565	TG-39	22
Q1106	07263	2N3565	TG-39	22
Q1107	07263	2N3565	TG-39	22
Q1108	07263	2N3565	TG-39	22
Q1109	07263	2N3565	TG-39	22
Q1110	07263	2N3565	TG-39	22

NOTE

On schematic diagram 23481E there are 6 buffers labeled 'A' through 'F'. Each buffer is composed of 5 resistors and 3 transistors. A sample buffer circuit is given on the schematic. Following below is a sample replaceable parts list for each buffer.

BUFFER RESISTORS (A thru F)

Circuit Desig.	Value	Rating	Type	Mfr. Code	Mfr. Part No.	Keithley Part No.	Fig. Ref.
R1121	10 k Ω	10%, 1/4 W	Comp	44655	RC07	R76-10K	22
R1122	120 k Ω	10%, 1/4 W	Comp	44655	RC07	R76-120K	22
R1123	10 k Ω	10%, 1/4 W	Comp	44655	RC07	R76-10K	22
R1124	180 k Ω	10%, 1/4 W	Comp	44655	RC07	R76-180K	22
R1125	3.9 k Ω	10%, 1/4 W	Comp	44655	RC07	R76-3.9K	22

BUFFER TRANSISTORS (A thru F)

Circuit Desig.	Mfr. Code	Mfr. Part No.	Keithley Part No.	Fig. Ref.
Q1111	07263	2N3565	TG-39	22
Q1112	07263	2N3565	TG-39	22
Q1113	07263	2N3565	TG-39	22

SECTION 5. CALIBRATION

5-1. GENERAL. This section contains information necessary to calibrate the instrument.

5-2. REQUIRED TEST EQUIPMENT. Recommended test equipment for checking and adjusting the instrument is given in Table 5-1.

5-3. ADJUSTMENT/CALIBRATION PROCEDURE.

NOTE 1.

To obtain rated accuracy, perform calibration at the ambient temperature of end use area, otherwise temperature coefficient correction factors must be used (see specifications). During calibration, the ambient temperature should be constant within $\pm 1^\circ\text{C}$. Relative humidity should be within range from 20 to 60%.

NOTE 2.

The top and bottom covers should be installed for A/D Converter and Picoammeter calibration. It is recommended that special punched top and bottom covers be fabricated. See Figures 34 and 35 for templates for covers. Alternately, the top cover may be removed for short periods of time. After adjustment, replace cover and allow instrument to stabilize for a few minutes before the cal. procedure is continued.

NOTE 3.

Care must be taken to minimize stray noise during calibration. Current sources should be isolated (floating) from ground. Model 445 should be also isolated. DVM should be grounded (except where noted).

a. Power Supply Adjustment. (Top and bottom covers must be removed for this adjustment).

1. Set LINE Switch to 117V or 234V if higher line voltage is only available. (Switch S101.)
2. Connect voltage of 115V ± 3 volts, or 234V ± 6 volts, 60 Hz (or 50 Hz, see note).

NOTE

If instrument is 50 Hz version, oscillator circuit should have 100kHz crystal installed on PC-217. (Y501, Keithley Part No. CR-2).

3. Turn on power (Switch S102).
4. Remove bottom cover and measure dc voltage at +15V test point on mother board on tape side of PC-221 using DVM (C).
5. Adjust potentiometer R115 for +15.000 $\pm 50\text{mV}$.
6. Check remaining regulated voltages as shown in Table 5-2.

TABLE 5-1.
Recommended Test Equipment for Calibration.

Item	Minimum Performance Required	Mfr.	Model
A	Current Source, Ranges: Variable from $1 \times 10^{-6}\text{A}$ to $1 \times 10^{-8}\text{A}$	Keithley	261
B	Current Source, Ranges: $\pm 1 \times 10^{-2}\text{A}$ to $1 \times 10^{-10}\text{A}$ Accuracy: $\pm 0.02\%$, from $1 \times 10^{-2}\text{A}$ to $1 \times 10^{-4}\text{A}$ $\pm 0.05\%$, from $1 \times 10^{-5}\text{A}$ to $1 \times 10^{-6}\text{A}$ $\pm 0.2\%$, $1 \times 10^{-7}\text{A}$ $\pm 0.3\%$, from $1 \times 10^{-8}\text{A}$ to $1 \times 10^{-9}\text{A}$ $\pm 0.5\%$, $1 \times 10^{-10}\text{A}$ (Source must have output capacitance less than 100pF) (Positive and negative tracking must be within one-half the maximum tolerance.)		
C	Digital Voltmeter (DVM), 5-1/2 digits, ± 10 microvolts to $\pm 20\text{V}$. Accuracy: $\pm 0.02\%$ of reading.	Keithley	190
D	Digital Counter, 100kHz or 120kHz $\pm 1\text{Hz}$	Eldorado	1507B
E	Oscilloscope (mainframe) Amplifier Plug-in, $1\text{mV}/\text{Div}$, DC to 500kHz Time-Base Plug-in, $5\text{ms}/\text{Div}$	Tektronix Tektronix Tektronix	561B 3A9 2B67
F	Null Detector, $\pm 10\mu\text{V}$ to $\pm 10\text{V}$, $\pm 2\%$ accuracy, $10^{12}\Omega$ isolation	Keithley	155

TABLE 5-2.
Power Supply Voltage Verification.

Voltage	Test Point	Tolerance
+15.000V	+15V	±50mV
-15.000V	-15V	±0.4V
+3.6V	+3.6V	±0.1V

b. Zero Adjust. (Top cover must be removed for these adjustments.)

1. Set front panel Zero Adjust (R1207) to mechanical center of adjustment span.
2. Set Display Rate to MAX.
3. Set Range to $10^{-2}A$.
4. Select ZERO CHECK, with no input signal connected.
5. Set Filter to OUT.
6. Connect Null Detector (F) to Model 445 ANALOG OUTPUT (J1218).
7. Connect DVM (must be floating) across resistor R1206 (18.2k Ω).
8. Adjust Coarse Zero (R1238) for 0 ± 2 millivolts at ANALOG OUTPUT (J1218).
9. Adjust Balance (R1202) for $5.2V \pm 0.1V$.
10. Repeat steps 8 through 9 until both readings are obtained simultaneously.
11. With Null Detector (F) connected, adjust front panel Zero Adjust (R1207) for $0 \pm 0.1mV$ at ANALOG OUTPUT (J1218).

c. Clock Adjust. (Top cover must be removed for this adjustment.)

1. Set Display Rate to MAX.
2. Set Filter to OUT.
3. Connect Counter (D) between "CLOCK" test point on printed circuit board PC-217 and "GND" test point on PC-219.
4. Adjust Frequency Adjust (C503) on PC-217 for a Counter reading of 120kHz \pm 1 Hz. (If Model 445 is 50 Hz version, set frequency for 100kHz \pm 1 Hz.)

NOTE

Capacitor C504 (22pF) may be added or removed to extend the adjustment range of trimmer C503.

d. Stabilization. Make certain internal shields and top/bottom covers are installed. With power on, allow the Model 445 to stabilize in the calibration area for two hours.

e. Picoammeter Range Calibration.

IMPORTANT

The range calibration must start on the $10^{-9}A$ range and progress towards the $10^{-2}A$ range since calibration of higher current ranges depends on calibration of all lesser ranges. Care must be exercised so as to avoid overloads on the lesser current ranges when in RANGE HOLD.

1. Set Display Rate to MAX.
2. Set Filter to OUT.
3. Place Range in HOLD.
4. Select $10^{-9}A$ range by downranging using the "DOWN" switch.
5. Select ZERO CHECK.
6. Connect DVM to ANALOG OUTPUT of Model 445.
7. Verify output of $0 \pm 0.1mV$.
8. Connect Current Source to Model 445 INPUT (J1213).
9. Apply $+1 \times 10^{-9}A$.
10. Adjust $10^{-9}A$ Cal. (R1235) to obtain $-1.05V \pm 0.1mV$ at ANALOG OUTPUT (J1218).
11. Complete remainder of current range calibration in accord with Table 5-3.

f. A/D Zero Adjustment.

1. Set Display Rate at MAX.
2. Set Filter to OUT.
3. Connect Oscilloscope as shown in Figure 32.
4. Connect DVM to analog output of Model 445.
5. Set range to $10^{-7}A$ and HOLD.
6. Place Model 445 in ZERO CHECK.
7. Adjust front panel Zero Adjust (R1207) for $0 \pm 0.1mV$ at ANALOG OUTPUT (J1218).
8. Set Oscilloscope to following:
 - a). With INTEGRATOR test point connected to vertical input, set vertical gain to 5mV/div., dc coupled.
 - b). With EXT. TRIGGER test point connected to horizontal input, set horizontal gain to 5ms/div., ac coupled.
 - c). Set trigger to EXT, +.

TABLE 5-3.
Current Range Accuracy Calibration.

Range	Input	Output Reading	Adjustment/Verification
$1 \times 10^{-9} \text{A}^*$	Zero Check +1 x 10^{-9}A -1 x 10^{-9}A +1 x 10^{-10}A -1 x 10^{-10}A	$0 \pm 0.1 \text{mV}$ $-1.05 \text{V} \pm 0.1 \text{mV}$ $+1.05 \text{V} \pm 0.3\%$ $-0.105 \text{V} \pm 0.8\%$ $+0.105 \text{V} \pm 0.8\%$	Verify Adjust 10^{-9} CAL. (R1235) Verify Verify Verify
$1 \times 10^{-8} \text{A}$	Zero Check +1 x 10^{-8}A -1 x 10^{-8}A +1 x 10^{-9}A -1 x 10^{-9}A	$0 \pm 0.1 \text{mV}$ $-1.05 \text{V} \pm 0.1 \text{mV}$ $+1.05 \text{V} \pm 0.3\%$ $-0.105 \text{V} \pm 0.6\%$ $+0.105 \text{V} \pm 0.6\%$	Verify Adjust 10^{-8} CAL. (R1234) Verify Verify Verify
$1 \times 10^{-7} \text{A}$	Zero Check +1 x 10^{-7}A -1 x 10^{-7}A +1 x 10^{-8}A -1 x 10^{-8}A	$0 \pm 0.1 \text{mV}$ $-1.05 \text{V} \pm 0.1 \text{mV}$ $+1.05 \text{V} \pm 0.2\%$ $-0.105 \text{V} \pm 0.5\%$ $+0.105 \text{V} \pm 0.5\%$	Verify Adjust 10^{-7} CAL. (R1232) Verify Verify Verify
$1 \times 10^{-6} \text{A}^{**}$	Zero Check** +1 x 10^{-6}A -1 x 10^{-6}A +1 x 10^{-7}A -1 x 10^{-7}A	$0 \pm 0.1 \text{mV}$ $-1.05 \text{V} \pm 0.1 \text{mV}$ $+1.05 \text{V} \pm 0.06\%$ $-0.105 \text{V} \pm 0.25\%$ $+0.105 \text{V} \pm 0.25\%$	Verify Adjust 10^{-6} CAL. (R1231) Verify Verify Verify
$1 \times 10^{-5} \text{A}^{**}$	Zero Check** +1 x 10^{-5}A -1 x 10^{-5}A	$0 \pm 0.1 \text{mV}$ $-1.05 \text{V} \pm 0.1 \text{mV}$ $+1.05 \text{V} \pm 0.06\%$	Verify Adjust 10^{-5} CAL. (R1221) Verify
$1 \times 10^{-4} \text{A}^{**}$	Zero Check** +1 x 10^{-4}A -1 x 10^{-4}A	$0 \pm 0.1 \text{mV}$ $-1.05 \text{V} \pm 0.2\%$ $+1.05 \text{V} \pm 0.2\%$	Verify Verify Verify
$1 \times 10^{-3} \text{A}^{**}$	Zero Check** +1 x 10^{-3}A -1 x 10^{-3}A	$0 \pm 0.1 \text{mV}$ $-1.05 \text{V} \pm 0.2\%$ $+1.05 \text{V} \pm 0.2\%$	Verify Verify Verify
$1 \times 10^{-2} \text{A}^{**}$	Zero Check** +1 x 10^{-2}A -1 x 10^{-2}A	$0 \pm 0.1 \text{mV}$ $-1.05 \text{V} \pm 0.1 \text{mV}$ $+1.05 \text{V} \pm 0.03\%$	Verify Adjust 10^{-2} CAL. (R1229) Verify

*If calibration of 10^{-9}A range is not possible, the problem may be a result of excessive offset current (less than $\pm 2 \times 10^{-13} \text{A}$ at factory calibration).

**Remove input source on these ranges when verifying zero.

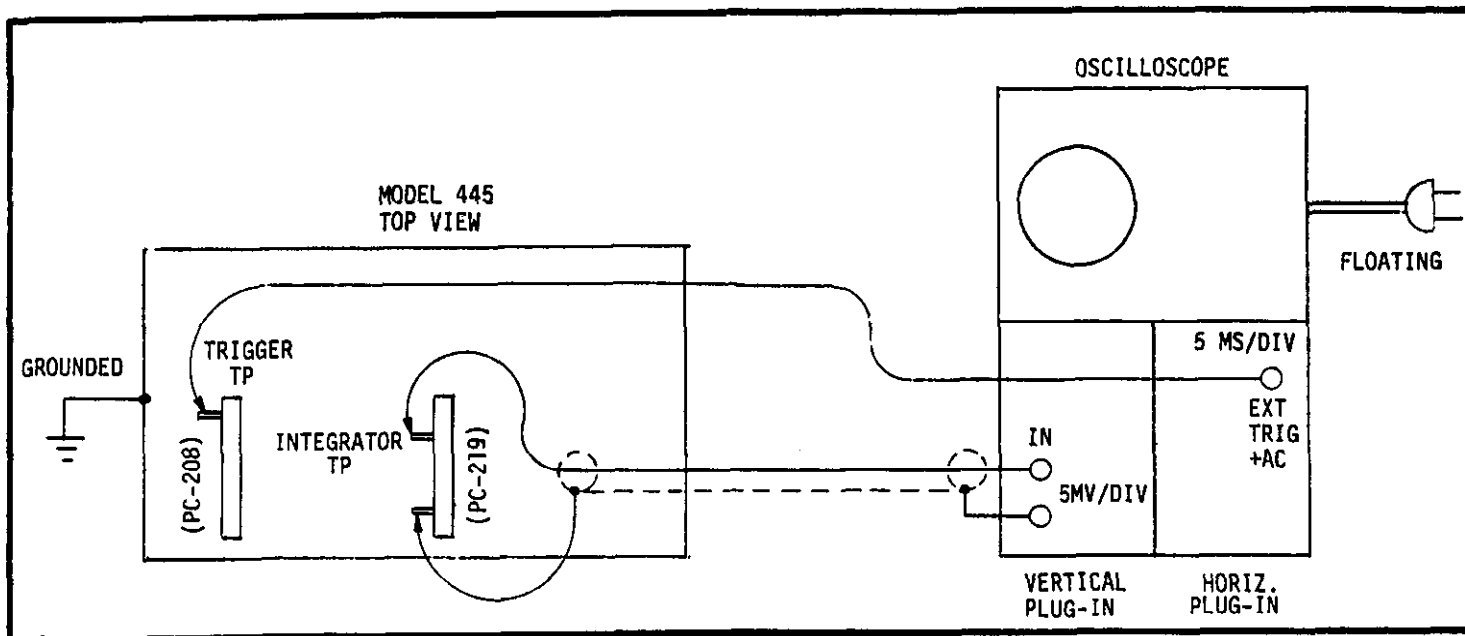

FIGURE 32. Test Equipment Set-up for A/D Calibration.

9. Adjust INTEGRATOR ZERO (R632) to minimize wave-form amplitude as shown in Figure 33.

10. Adjust ZERO CROSSING ADJ. (R649) to minimize wave-form amplitude as shown in Figure 33. Increase Oscilloscope vertical sensitivity as necessary (to 1mV/div, dc coupled).

NOTE

If range of adjustment of INTEGRATOR ZERO (R632) is insufficient add or remove jumpers across resistors R630 and R631.

11. Set vertical oscilloscope input to GND (using AC/DC/GND switch) to set reference "0" position. Switch to DC and verify that RESET position coincides with "0".

12. With RESET adjusted on oscilloscope grid line, adjust INTEGRATOR ZERO to set "Integrator" waveform within $\pm 0.1mV$ of RESET position.

13. Adjust ZERO CROSSING ADJ. (R649) to obtain a zero reading on the Model 445 display such that the polarity indicator flashes + and -.

14. Remove Oscilloscope and other leads from Model 445.

g. A/D Linearity Adjust.

1. Connect Current Source (A) to Model 445 INPUT.
2. Open ZERO CHECK.
3. Apply a positive input current to Model 445.
4. Adjust Current Source and front panel zero as necessary for ANALOG OUTPUT reading of $-2.0995V \pm 0.1mV$.

5. Adjust + REF. Control (R611, PC-219) for a Model 445 display flashing between +1.999 and blank.

NOTE

Add or remove jumper wires which shunt resistors R608, R609, or R610 (on printed circuit board PC-219) to extend the range of adjustment on potentiometer R611. Resistor R607 may be changed if necessary.

6. Apply a minus input current to Model 445.

7. Adjust Current Source and front panel zero as necessary for ANALOG OUTPUT reading of $+2.0995V \pm 0.1mV$.

8. Adjust - REF. Control (R606, PC-219) for a Model 445 display flashing between -1.999 and blank.

NOTE

Add or remove jumper wires which shunt resistors R603, R604, or R605 (on printed circuit board PC-219) to extend the range of adjustment on potentiometer R606. Resistor R602 may be changed if necessary.

9. Remove Current Source.

10. Place Model 445 in ZERO CHECK.

11. Adjust front panel Zero Control for ANALOG OUTPUT of $0 \pm 0.1mV$.

12. Model 445 display should indicate ± 000 .

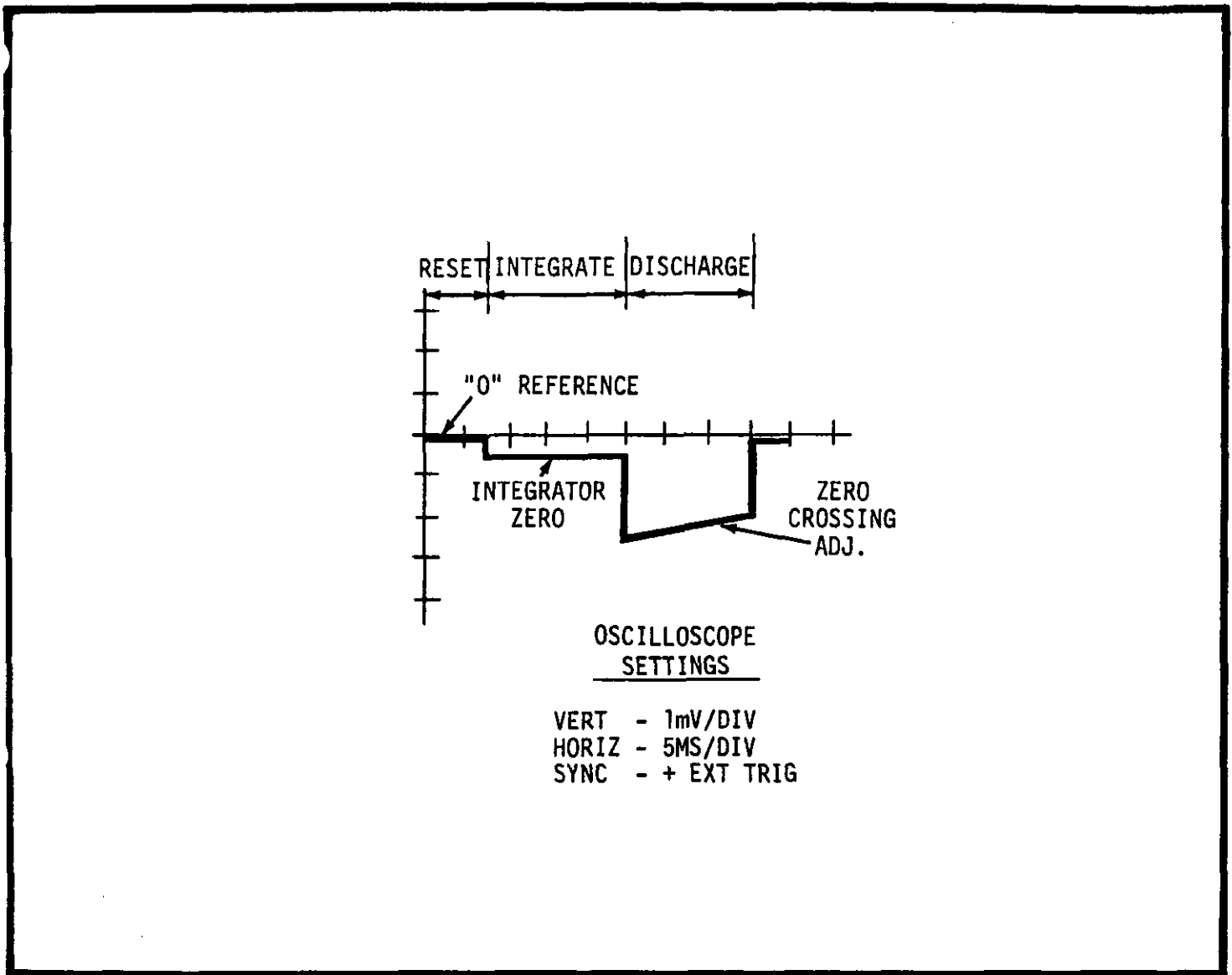

FIGURE 33. A/D Converter Zero Adjustments.

CODE-TO-NAME LIST.

Code List of Suggested Manufacturers. (Based on Federal Supply Code for Manufacturers, Cataloging Handbook H4-1)

01121	Allen-Bradley Corp. 1201 South 2nd Street Milwaukee, Wis. 53204	13050	Potter Co. Highway 51 N. Wesson, Miss. 39191	73138	Beckman Instruments, Inc. Helipot Division 2500 Harbor Blvd. Fullerton, Cal. 92634
01295	Texas Instruments, Inc. Semiconductor-Components Div. 13500 No. Central Expressway Dallas, Texas 75231	13327	Solitron Devices, Inc. 256 Oak Tree Road Tappan, N.Y. 10983	73445	Amperex Electronic Co. Div. of North American Philips Co. Inc. Hicksville, N.Y.
01686	RCL Electronics, Inc. 195 McGregor Street Manchester, N.H. 03102	13934	Midwec Corp. 602 Main Oshkosh, Nebr. 69154	73690	Elco Resistor Co. 1158 Broadway New York, N.Y.
02660	Amphenol Corp. 2801 South 25th Avenue Broadview, Ill. 60153	17554	Components, Inc. Smith Street Biddeford, Maine 04005	75915	Littlefuse, Inc. 800 E. Northwest Hwy. Des Plaines, Ill. 60016
02734	Radio Corp. of America Defense Electronic Products Camden, N.J.	24655	General Radio Co. 22 Baker Avenue West Concord, Mass. 01781	80164	Keithley Instruments, Inc. 28775 Aurora Road Cleveland, Ohio 44139
02735	Radio Corp. of America Commercial Receiving Tube and Semiconductor Division Somerville, N.J.	27682	Hathaway Instruments, Inc. 5800 E. Jewell Avenue Denver, Colorado 80222	83594	Burroughs Corp. Electronic Components Div. Post Office Box 1226 Plainfield, N.J. 07061
03508	General Electric Company Semiconductor Products Dept. Electronics Park Syracuse, New York 13201	44655	Ohmite Mfg. Co. 3601 Howard Street Skokie, Ill. 60076	84171	Arco Electronics, Inc. Community Drive Great Neck, N.Y. 11022
04713	Motorola Semiconductor Products Inc. 5005 East McDowell Rd. Phoenix, Ariz. 85008	58474	Superior Electric Co.,The 383 Middle St. Bristol, Conn. 06012	84790	Dura Corporation Implement Division Post Office Box 231 Zanesville, Ohio 43702
05397	Union Carbide Corp. Electronics Division 270 Park Avenue New York, N.Y. 10017	71279	Cambridge Thermionic Corp. 430 Concord Avenue Cambridge, Mass.	90201	Mallory Capacitor 3029 East Washington Post Office Box 372 Indianapolis, Ind. 46206
07263	Fairchild Camera and Instrument Corp. Semiconductor Division 313 Frontage Road Mountain View, Cal.	71400	Bussmann Mfg. Div. of McGraw-Edison Co. 2538 W. University St. St. Louis, Mo.	91637	Dale Electronics, Inc. P.O. Box 609 Columbus, Nebr. 68601
07716	IRC, Inc. 2850 Mt. Pleasant Burlington, Iowa 52601	71450	CTS Corp. 1142 W. Beardsley Ave. Elkhart, Ind.	91662	Elco Corp. Willow Grove, Pa.
09922	Burndy Corp. Richards Avenue Norwalk, Conn. 06852	71590	Centralab Division of Globe-Union, Inc. 932 E. Keefe Ave. Milwaukee, Wis. 53212	91802	Industrial Devices Inc. 982 River Rd. Edgewater, N.J. 07020
12040	National Semiconductor Corp. Commerce Drive Post Office Box 443 Danbury, Conn. 06813	72982	Erie Technological Products, Inc. 644 W. 12th St. Erie, Pa. 16512	93656	Electric Cord Co. 1275 Bloomfield Ave. Caldwell, N.J.
				95712	Dage Electric Co., Inc. Hurricane Road Franklin, Indiana

REV	DATE	BY
1		

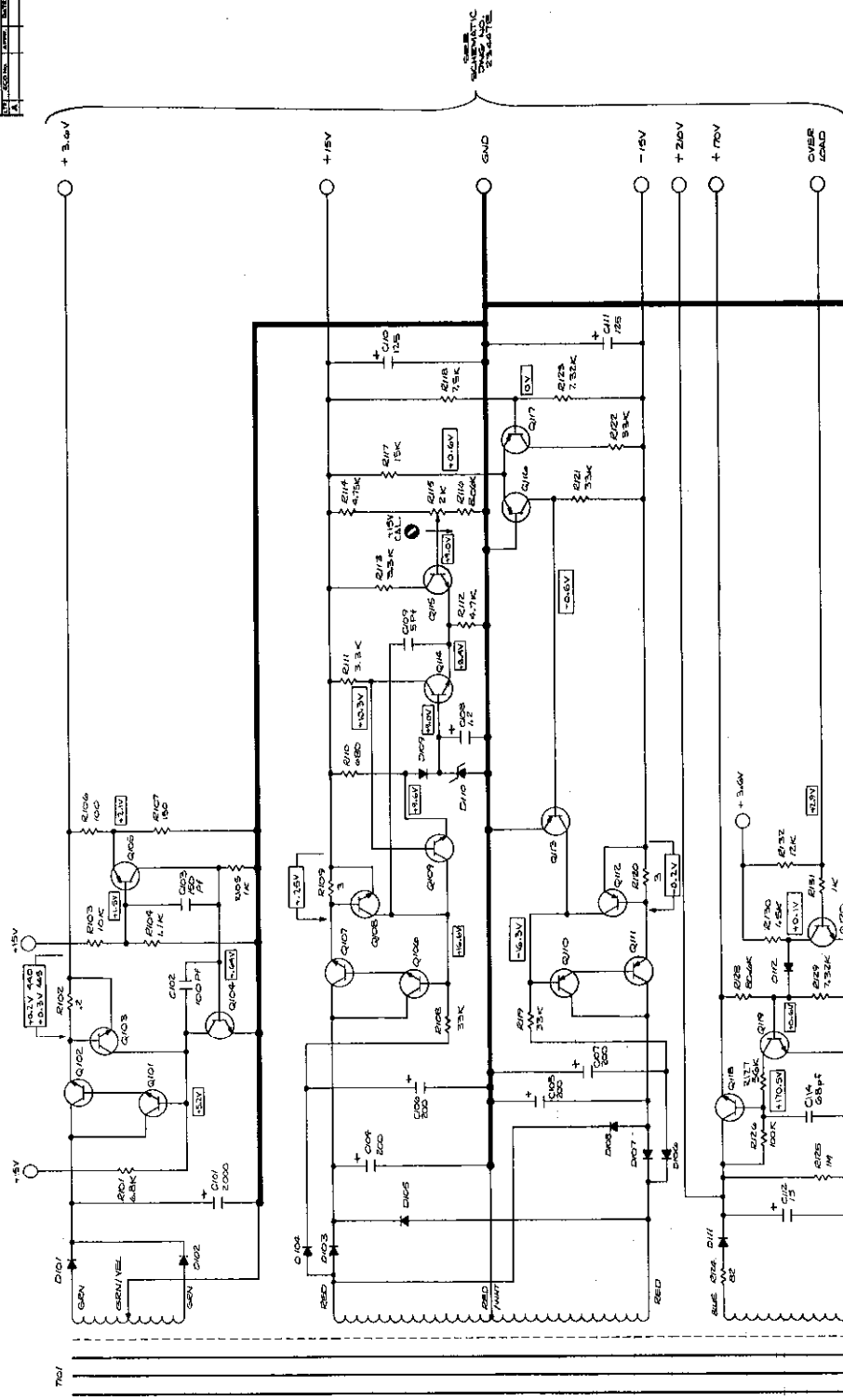

NOTES:

1. ALL REFERENCE CHARACTERISTICS SHALL BE DISCONTINUED IN CHARTS AND MICROFILMS RESPECTIVELY UNLESS OTHERWISE NOTICED.
2. ① ABOUT PANEL CONTROL.
3. ② INTERNAL SCHEMATIC NOT.
4. ③ OVER PANEL CONTROL.
5. ④ C.W. RETENTION.
6. ⑤ M = PROGRAMS.
7. ⑥ M = MICROFILMS.
8. ⑦ K = KODAK.
9. ⑧ K = KODAK.
10. ⑨ TO CHANGE, GROUND WITH ALL BOARDS INSTALLED, INSTRUMENT IN ZERO CHECK.

REV	DATE	BY
1		

TITLE: **HEATHLEY INSTRUMENTS POWER SUPPLY**
 DRAWING NO.: **23448E**
 DATE: **11/17/60**
 BY: **WJK**
 CHECKED: **WJK**
 APPROVED: **WJK**
 DO NOT SCALE

DESIGNER	DATE	BY

DESIGNER	DATE	BY

DESIGNER	DATE	BY

DESIGNER	DATE	BY

DESIGNER	DATE	BY

REV	DATE	BY	CHKD
1	3-7-68	WJW	WJW

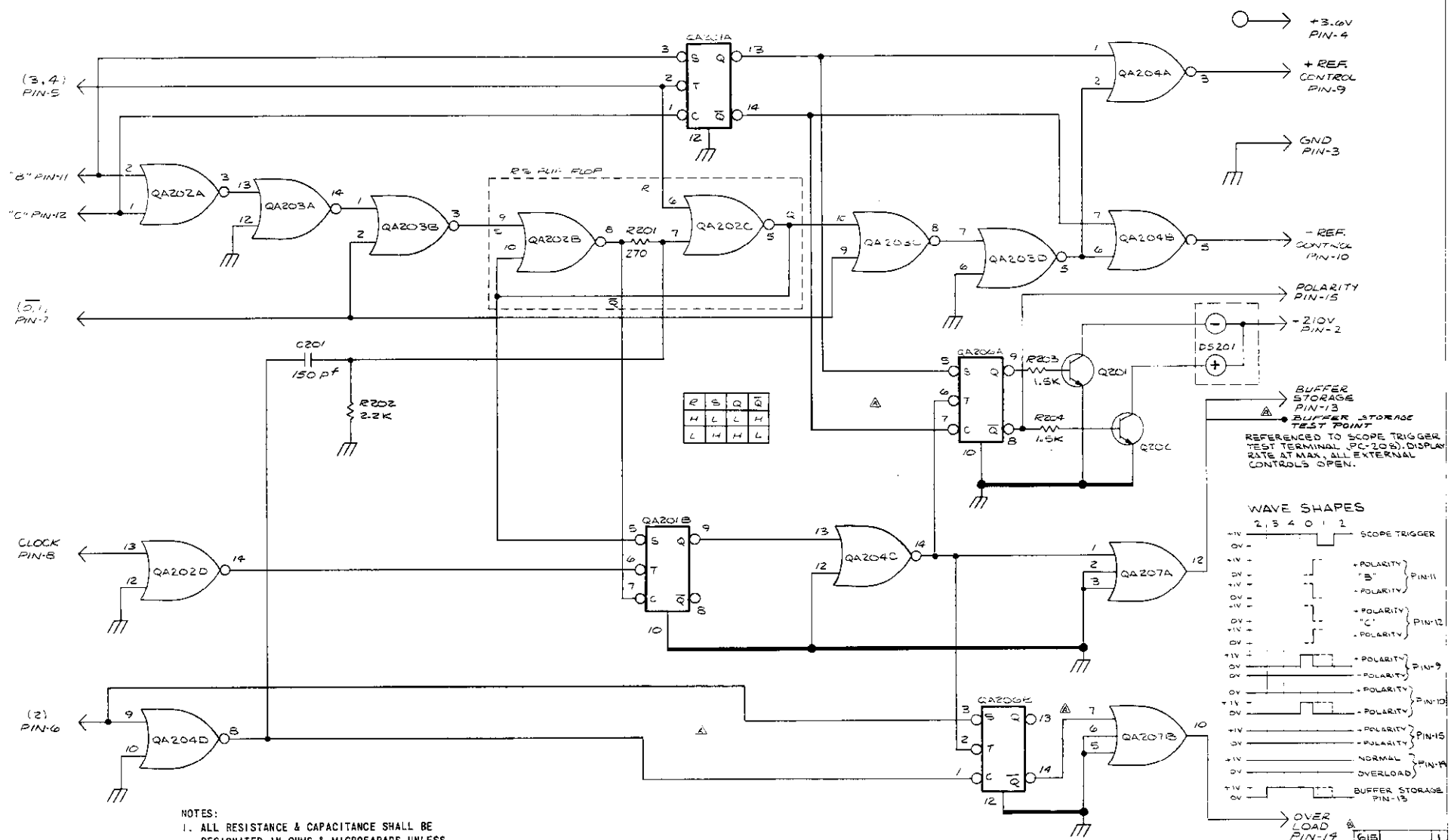

NOTES:
 1. ALL RESISTANCE & CAPACITANCE SHALL BE DESIGNATED IN OHMS & MICROFARADS UNLESS OTHERWISE NOTED.
 2. K - 1000 OHMS pf - PICOFARAD

R	S	Q	H
H	L	L	H
L	H	H	L

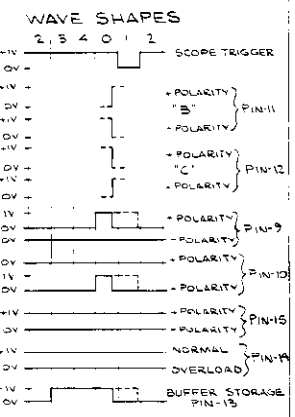

HIGHEST REFERENCE DESIGNATIONS			
R20A	C201	D5201	Q202
QA207			

REFERENCE DESIGNATIONS NOT USED			
QA205			

DATE	3-7-68	BY	WJW	CHKD	WJW
REV	1	DATE		BY	
DIMENSIONAL TOLERANCES UNLESS OTHERWISE SPECIFIED					
FRACTIONS DECIMALS ANGLES					
FRACTIONS .125 .250 .375 .500 .750 1.000 1.250 1.500 1.750 2.000 2.250 2.500 2.750 3.000 3.250 3.500 3.750 4.000 4.250 4.500 4.750 5.000 5.250 5.500 5.750 6.000 6.250 6.500 6.750 7.000 7.250 7.500 7.750 8.000 8.250 8.500 8.750 9.000 9.250 9.500 9.750 10.000					
DECIMALS .005 .010 .015 .020 .025 .030 .035 .040 .045 .050 .055 .060 .065 .070 .075 .080 .085 .090 .095 .100 .105 .110 .115 .120 .125 .130 .135 .140 .145 .150 .155 .160 .165 .170 .175 .180 .185 .190 .195 .200 .205 .210 .215 .220 .225 .2					

REVISIONS			
NO.	REASON	DATE	BY
A			

REFERENCED TO SCOPE TRIGGER
TEST TERMINAL (PC-208), DISPLAY
RATE AT MAX, ALL EXTERNAL
CONTROLS OPEN.

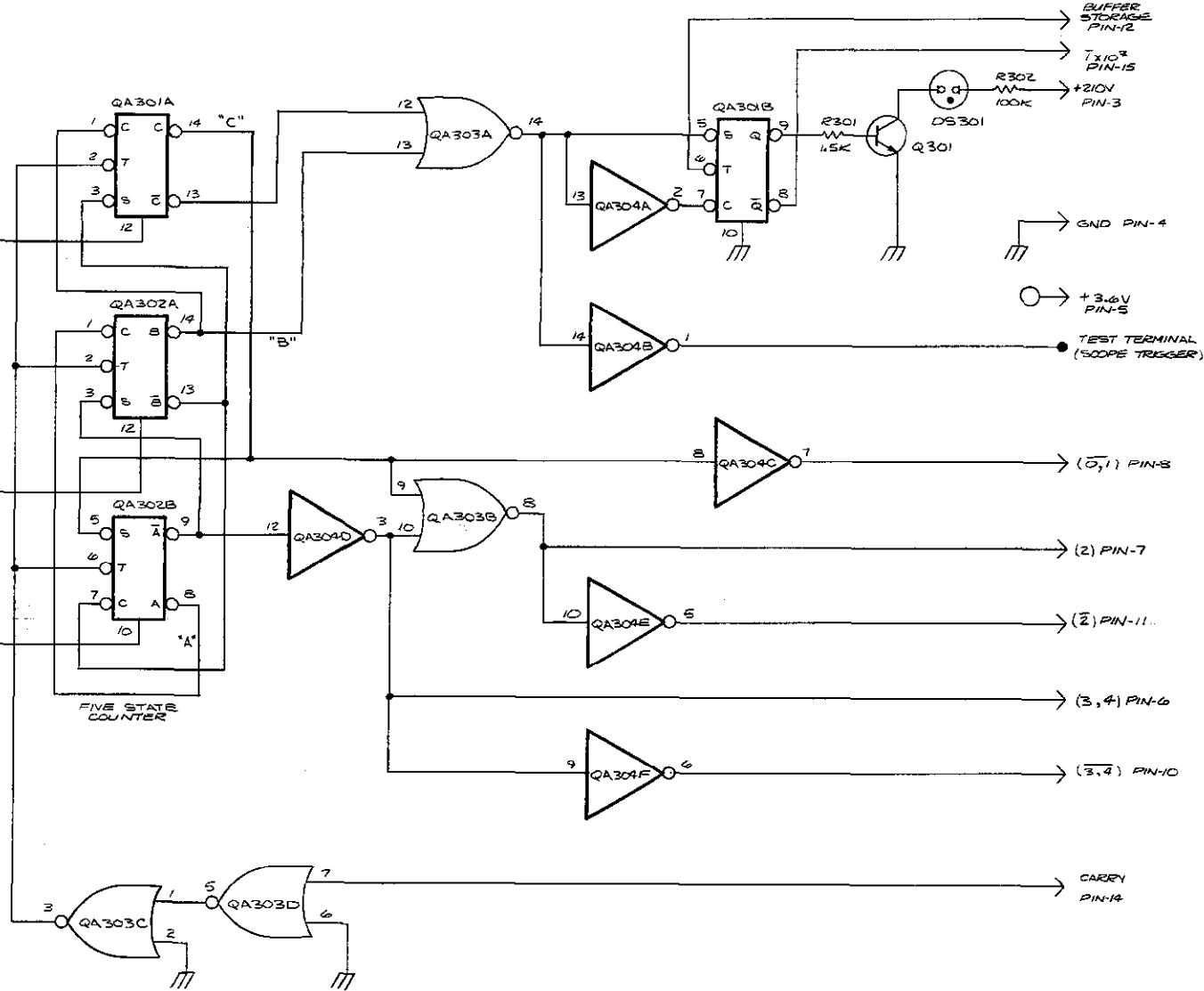
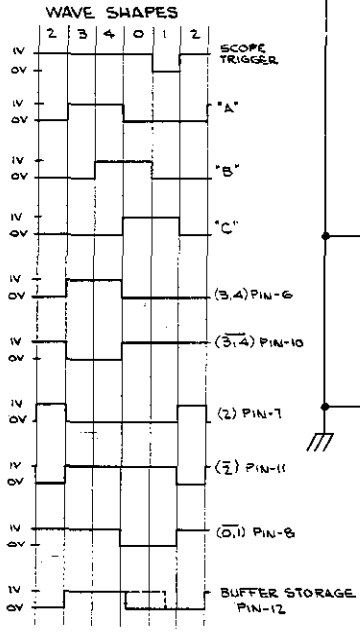

NOTES:
1. K = 1000 OHMS

HIGHEST REFERENCE DESIGNATION'S	
R302	DS301, Q301, QA304

REFERENCE DESIGNATION'S NOT USED	

DIMENSIONAL TOLERANCES UNLESS OTHERWISE SPECIFIED	
FRAC.	DEC.
2 U.S.A. 2.000 0.1"	
PROOF	DATE 3/1/64
REWORK	DATE 3/1/64
RELEASE	DATE

 KEITHLEY INSTRUMENTS CLEVELAND, OHIO	TITLE SCHEMATIC PC-208 THOUSAND BOARD	PART NUMBER 23450D
---	--	------------------------------

REVISIONS
 NO. 1000 - 1000000
 A-800-001 (1000-10)

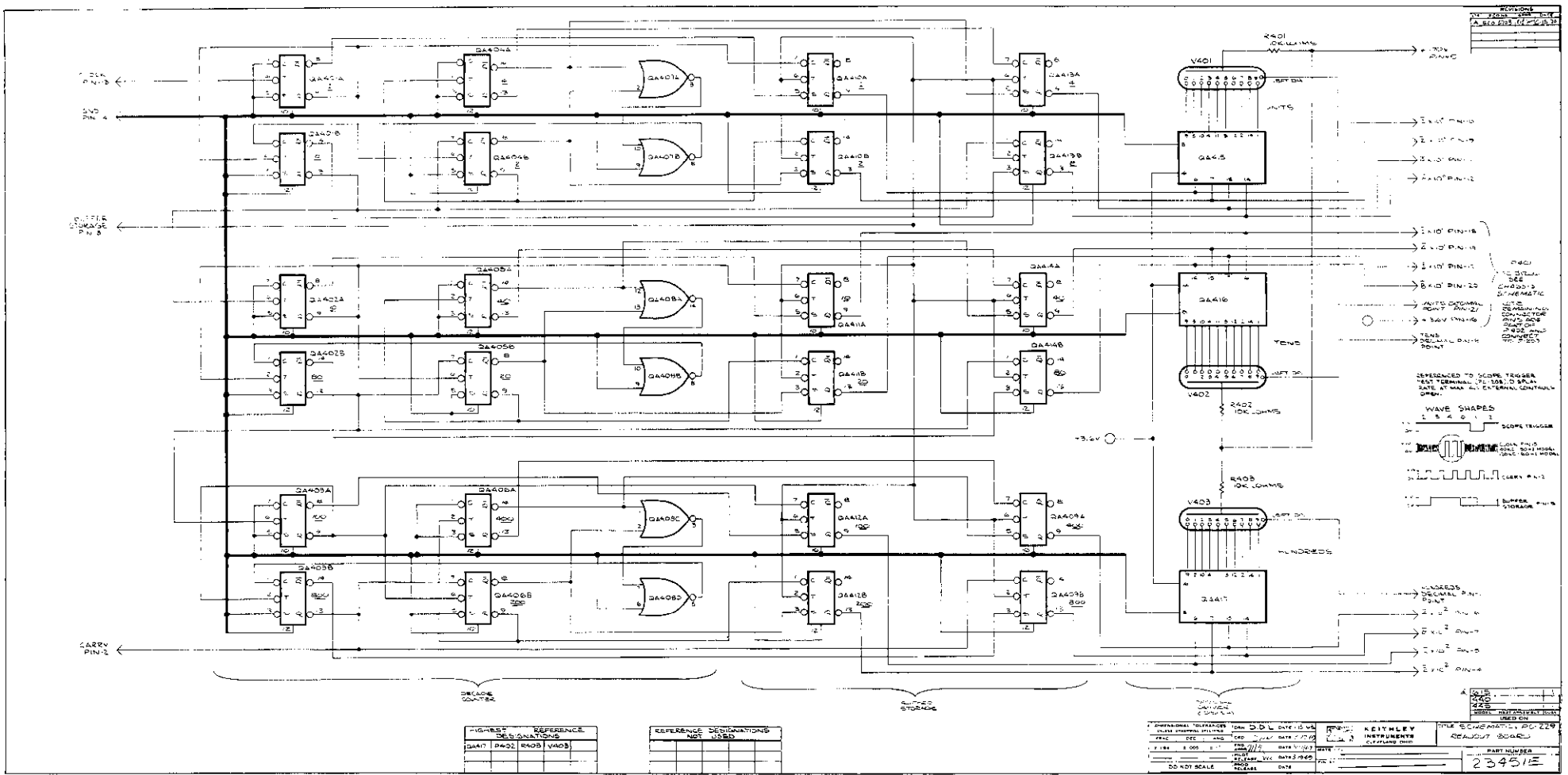

HIGHEST REFERENCE DESIGNATIONS	REFERENCE DESIGNATIONS NOT USED
2A407	
2A402	
2A403	
2A405	

REFERENCE DESIGNATIONS NOT USED

OPERATIONAL INSTRUCTIONS	ISSUE D.D.L. DATE 10/5/58	REVISED BY KEITHLEY INSTRUMENTS	FILE SCHEMATIC, DC-229
DESIGNER	DATE 10/5/58	APPROVED BY	DESIGN BOARD
TESTER	DATE 10/5/58	DATE 10/5/58	
DO NOT SCALE	SCALE	DATE	PART NUMBER 23401E

*if display blanks out with power on, or no response
check the ref. control signals.*

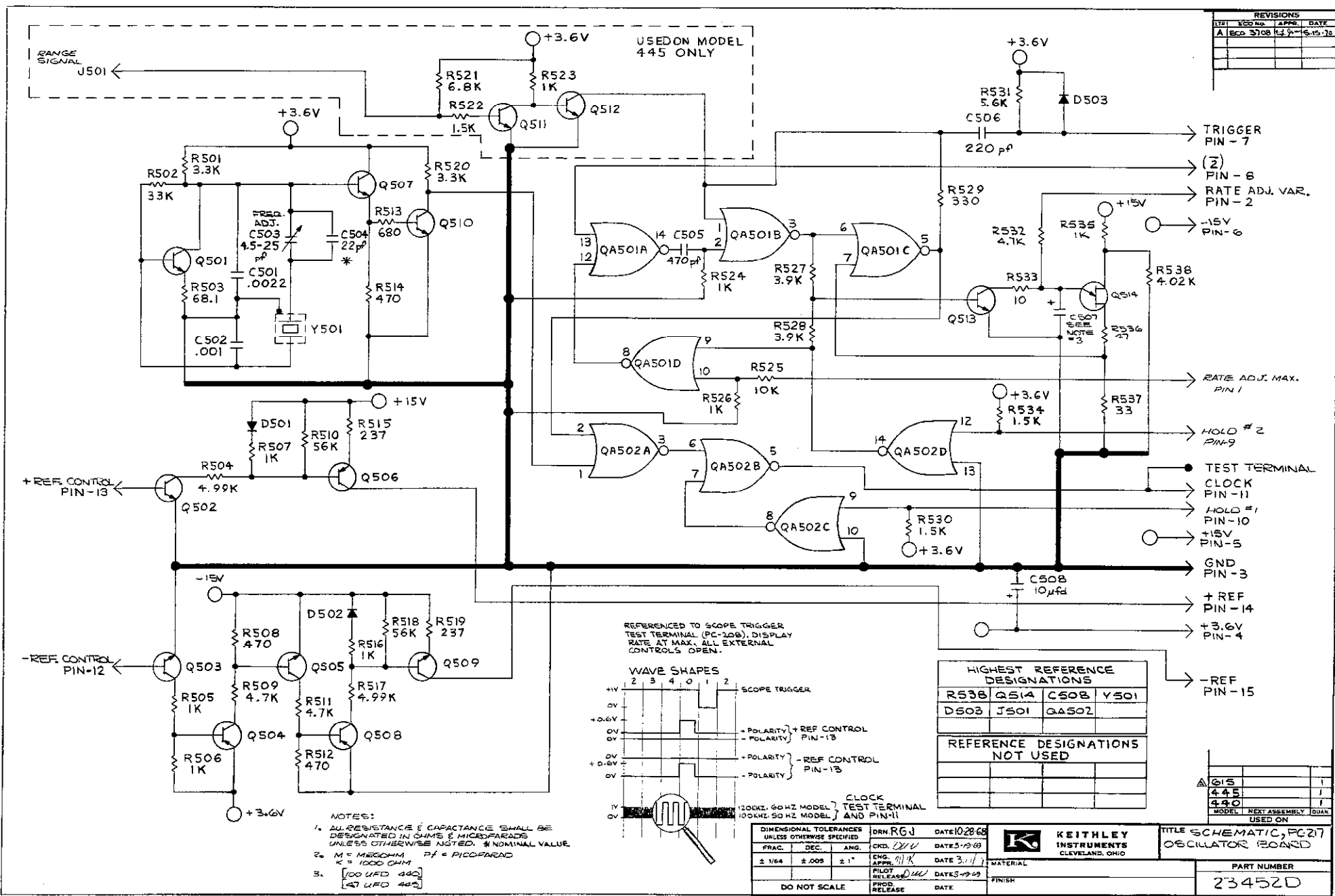

REVISIONS		
REV.	ISS. NO.	DATE
A	ECO 3708	6-15-78

REFERENCED TO SCOPE TRIGGER
TEST TERMINAL (PC-208), DISPLAY
RATE AT MAX. ALL EXTERNAL
CONTROLS OPEN.

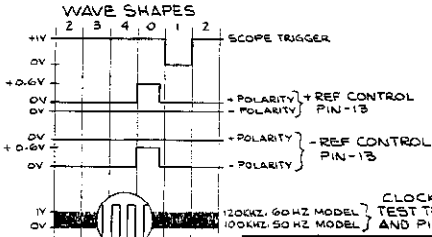

HIGHEST REFERENCE DESIGNATIONS			
R538	Q514	C508	Y501
D503	J501	Q502	

REFERENCE DESIGNATIONS NOT USED			

- NOTES:
- ALL RESISTANCE & CAPACITANCE SHALL BE DESIGNATED IN OHMS & MICROFARADS UNLESS OTHERWISE NOTED. * NOMINAL VALUE.
 - M = MEGOHM P = PICOFARAD
 - | | |
|---------|-----|
| 100 UFD | 490 |
| 47 UFD | 495 |

DIMENSIONAL TOLERANCES UNLESS OTHERWISE SPECIFIED			DRN RGJ DATE 10/28/68	
FRACTION	DEC.	ANG.	CHK. <i>OW</i>	DATE 3-9-69
± 1/64	± .005	± 1°	ENG. <i>OW</i>	DATE 3-11
DO NOT SCALE			PILOT RELEASE <i>OW</i>	DATE 5-9-69
			PRD. RELEASE	DATE

KEITHLEY INSTRUMENTS
CLEVELAND, OHIO

TITLE SCHEMATIC, PC217
OSCILLATOR BOARD

PART NUMBER
23452D

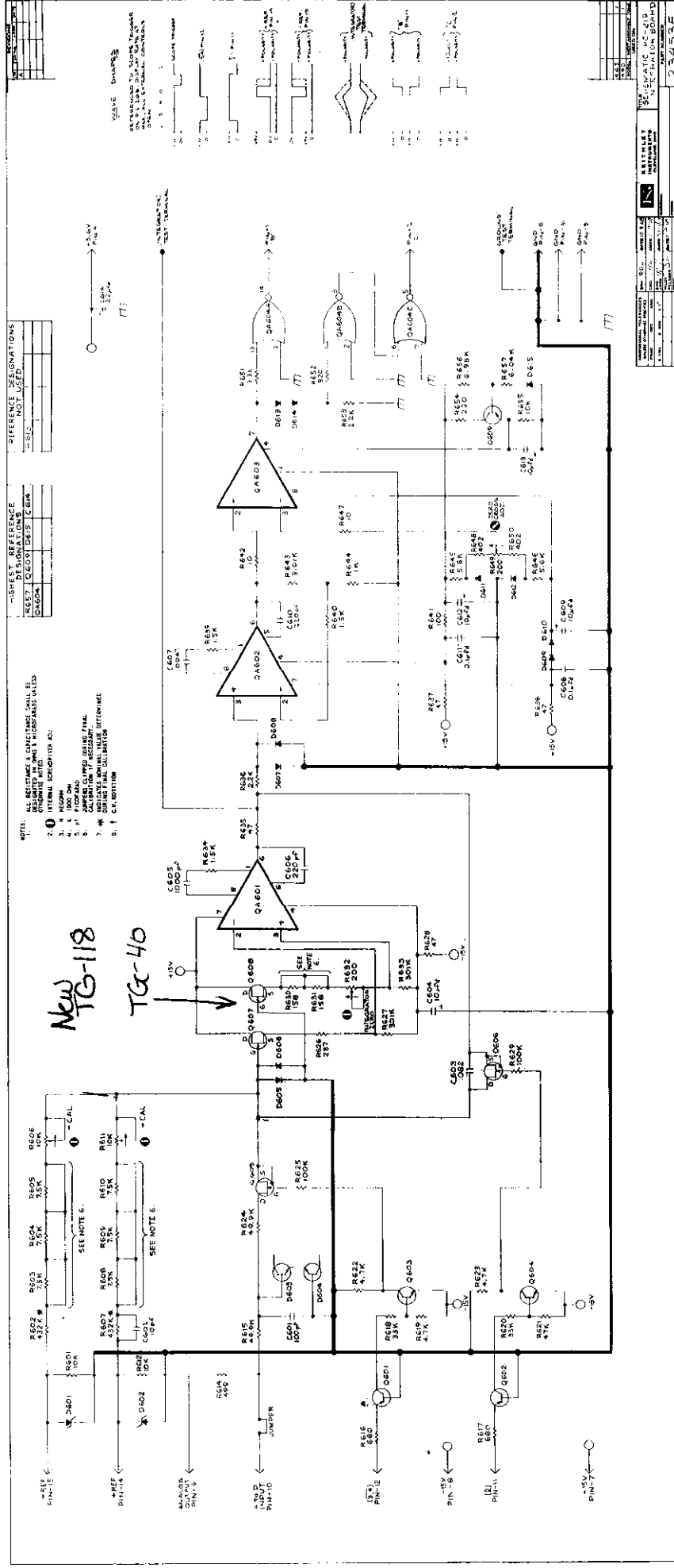
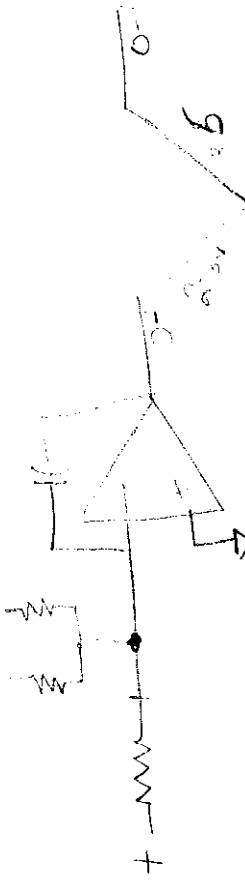

REVISIONS

NO.	DATE	DESCRIPTION
1	11/15/68	INITIAL DESIGN
2	11/15/68	REVISED TO ADD TEST POINTS
3	11/15/68	REVISED TO ADD TEST POINTS
4	11/15/68	REVISED TO ADD TEST POINTS
5	11/15/68	REVISED TO ADD TEST POINTS
6	11/15/68	REVISED TO ADD TEST POINTS
7	11/15/68	REVISED TO ADD TEST POINTS
8	11/15/68	REVISED TO ADD TEST POINTS
9	11/15/68	REVISED TO ADD TEST POINTS
10	11/15/68	REVISED TO ADD TEST POINTS

DESIGNER: [Signature]

CHECKED: [Signature]

DATE: 11/15/68

23453E

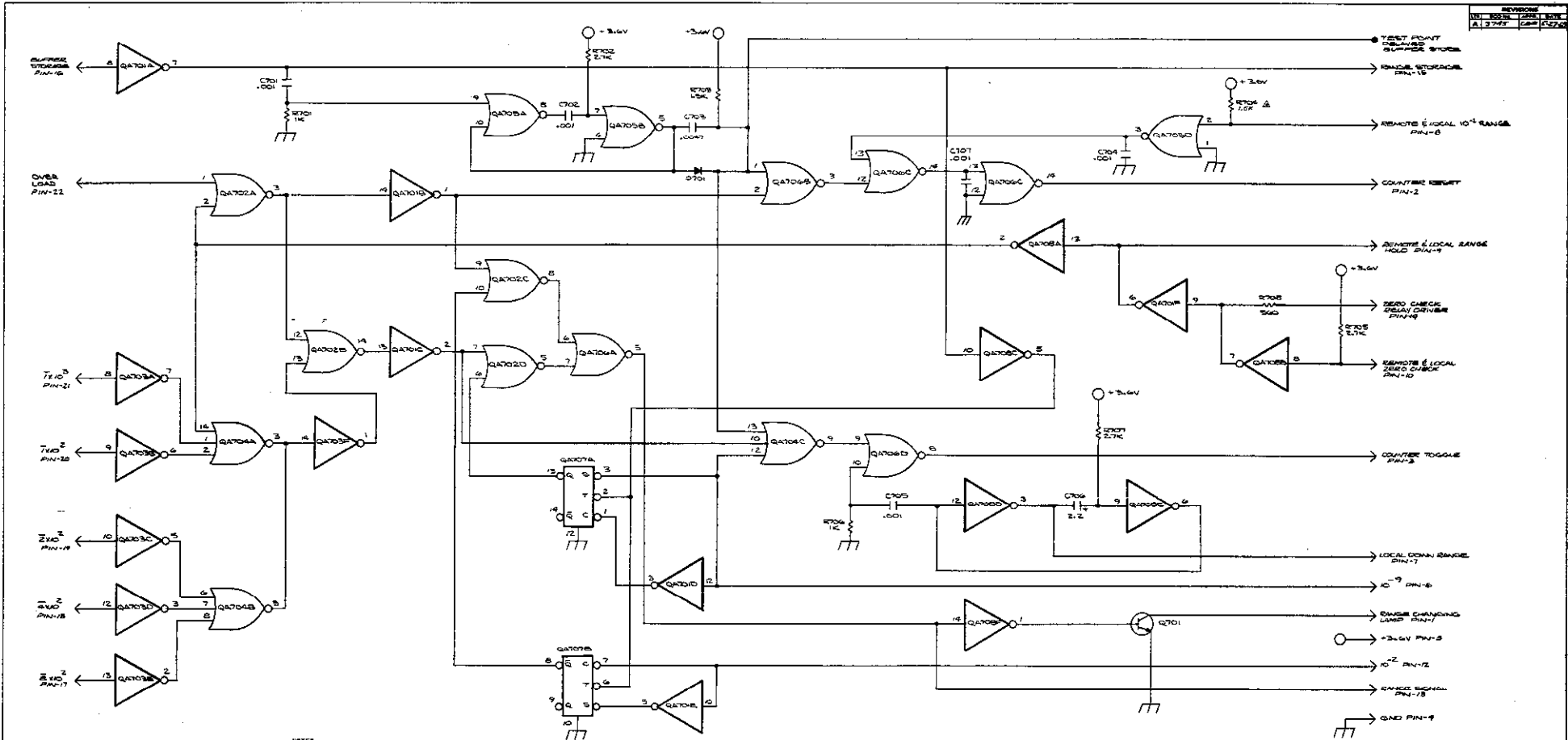

NOTES:
 1. ALL RESISTANCE & CAPACITANCE SHALL BE DESIGNATED IN OHMS & MICROFARADS UNLESS OTHERWISE NOTED.
 2. K = 1000 OHMS

HIGHEST REFERENCE DESIGNATIONS			
Q701	Q702	Q703	Q704

ADDITIONAL DESIGNATIONS NOT USED			

DIMENSIONAL TOLERANCES UNLESS OTHERWISE SPECIFIED			
FRAMES	FRAMES	FRAMES	FRAMES

KEITHLEY INSTRUMENTS CLEVELAND, OHIO	TITLE SCHEMATIC INSTRUMENTS CONTROL BOARD	PART NUMBER 23454E
--	--	------------------------------

REVISIONS			
1	INITIALS	DATE	DESCRIPTION

REVISIONS			
NO.	DESCRIPTION	DATE	BY
1			

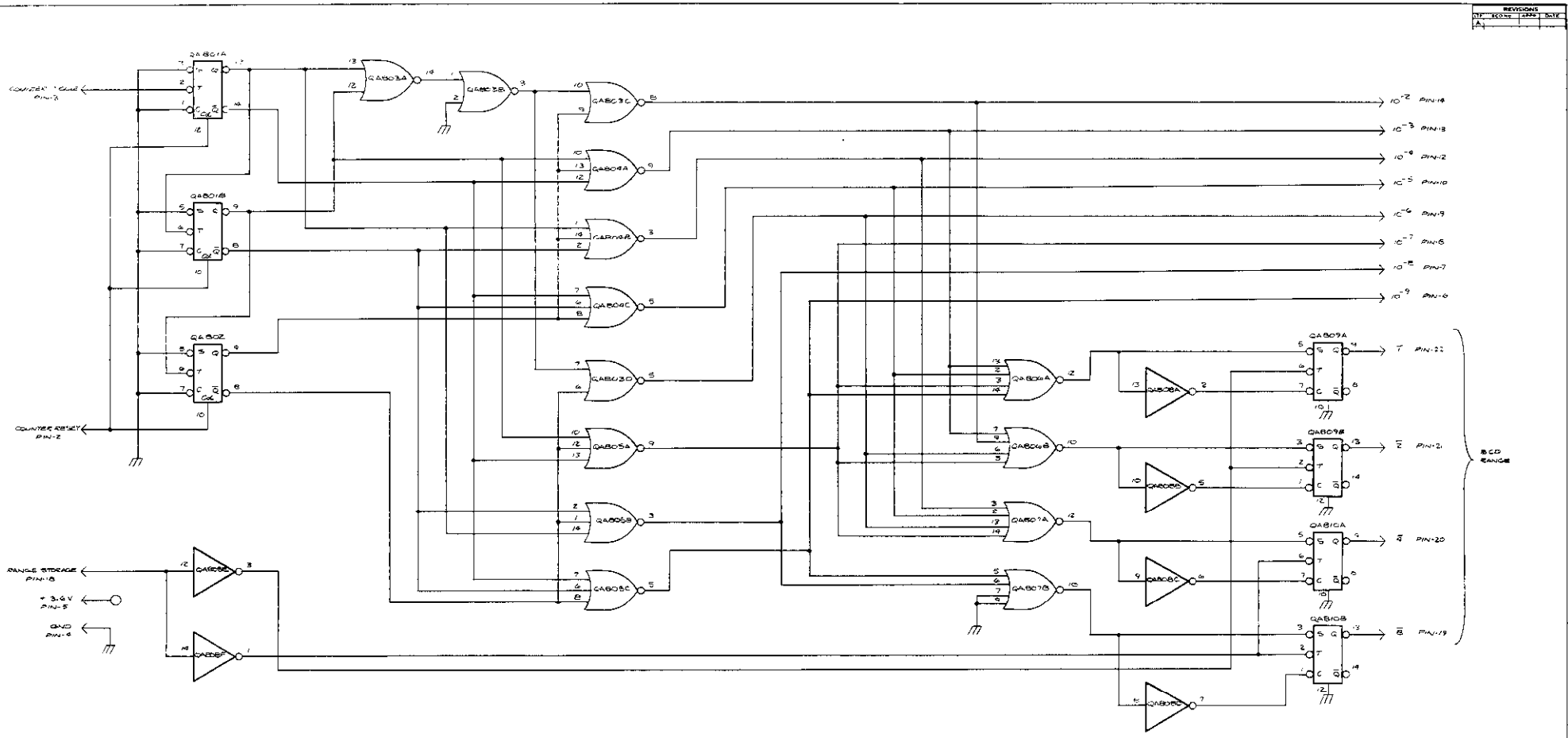

HIGHEST RESISTANCE DESIGNATION

REFERENCE DESIGNATIONS NOT USED

DIMENSIONAL TOLERANCES UNLESS OTHERWISE SPECIFIED FRACTIONS DECIMALS ANGLES .015 .001 1.1° FINISH DO NOT SCALE	DIM. CHECKED DATE/10/10/62 DESIGNED BY DATE/10/10/62 DRAWN BY DATE/10/10/62 CHECKED BY DATE/10/10/62 RELEASE DATE	KREITZLEY INSTRUMENTS CLEVELAND OHIO	TITLE SCHEMATIC IC-2/2 RANGE COUNTER / DECODER BOARD PART NUMBER 23435E
---	---	---	---

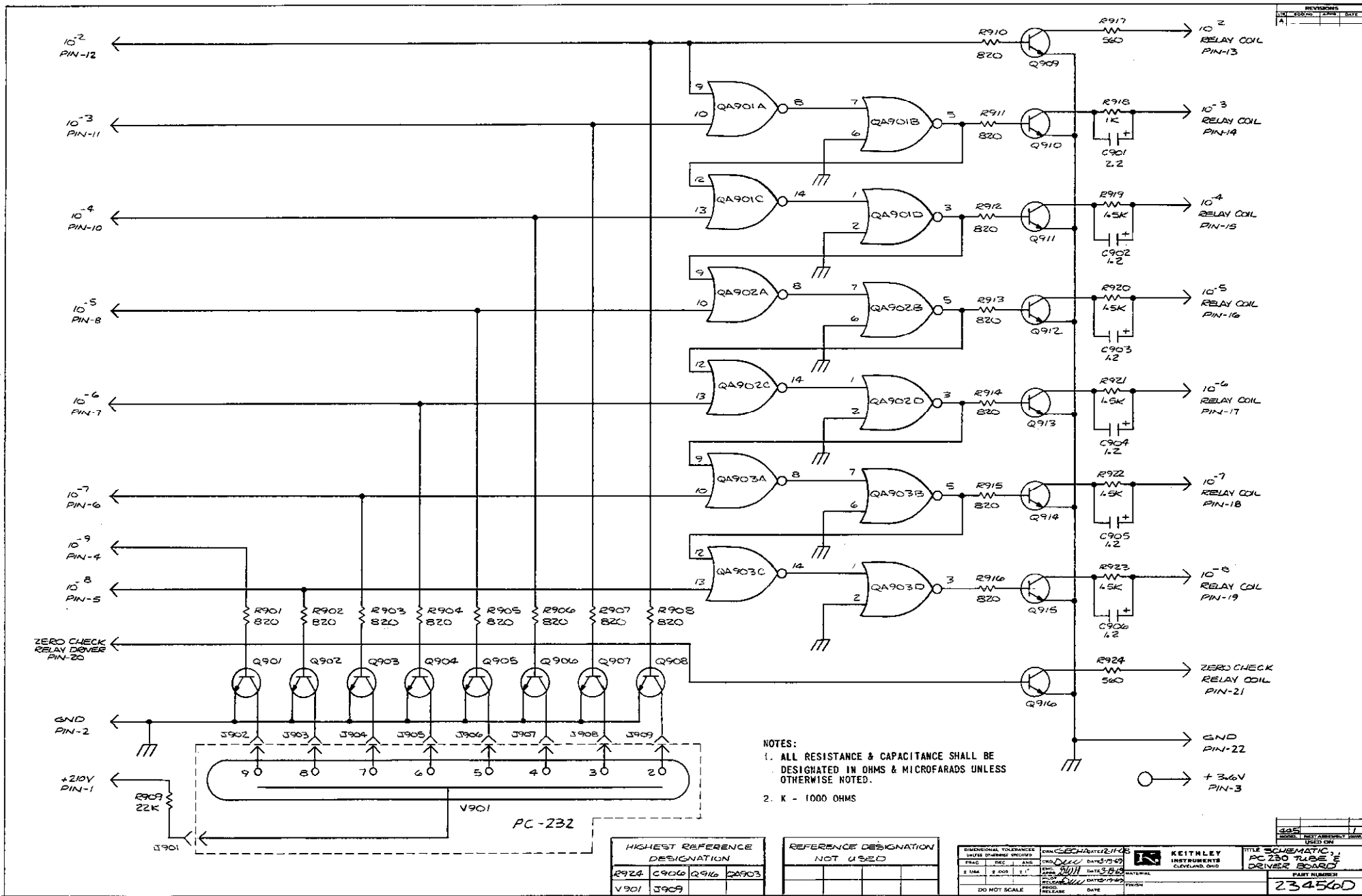

- NOTES:
1. ALL RESISTANCE & CAPACITANCE SHALL BE DESIGNATED IN OHMS & MICROFARADS UNLESS OTHERWISE NOTED.
 2. K - 1000 OHMS

HIGHEST REFERENCE DESIGNATION			
R924	C906	Q916	QA903
V901	J909		

REFERENCE DESIGNATION NOT USED			

DIMENSIONAL TOLERANCES UNLESS OTHERWISE SPECIFIED: FINISH: .0005" .001" .002" .005" .010" DIM: .001" .002" .005" .010" .020" .050" .100" HOLE: .001" .002" .005" .010" .020" .050" .100" DO NOT SCALE	DESIGNED BY: SCHWARTZ/108 DATE: 3-26-64 CHECKED BY: [Signature] DATE: 3-26-64 DRAWN BY: [Signature] DATE: 3-26-64 MATERIAL: [Blank] FINISH: [Blank]	KEITHLEY INSTRUMENTS CLEVELAND, OHIO TITLE: SCHEMATIC PART NUMBER: PC 230 TUBE DRIVER BOARD PART NUMBER: 23456D
---	--	--

REVISIONS			
NO.	DESCRIPTION	DATE	BY
1A			

REVISIONS			
REV.	DESCRIPTION	DATE	BY
1A			

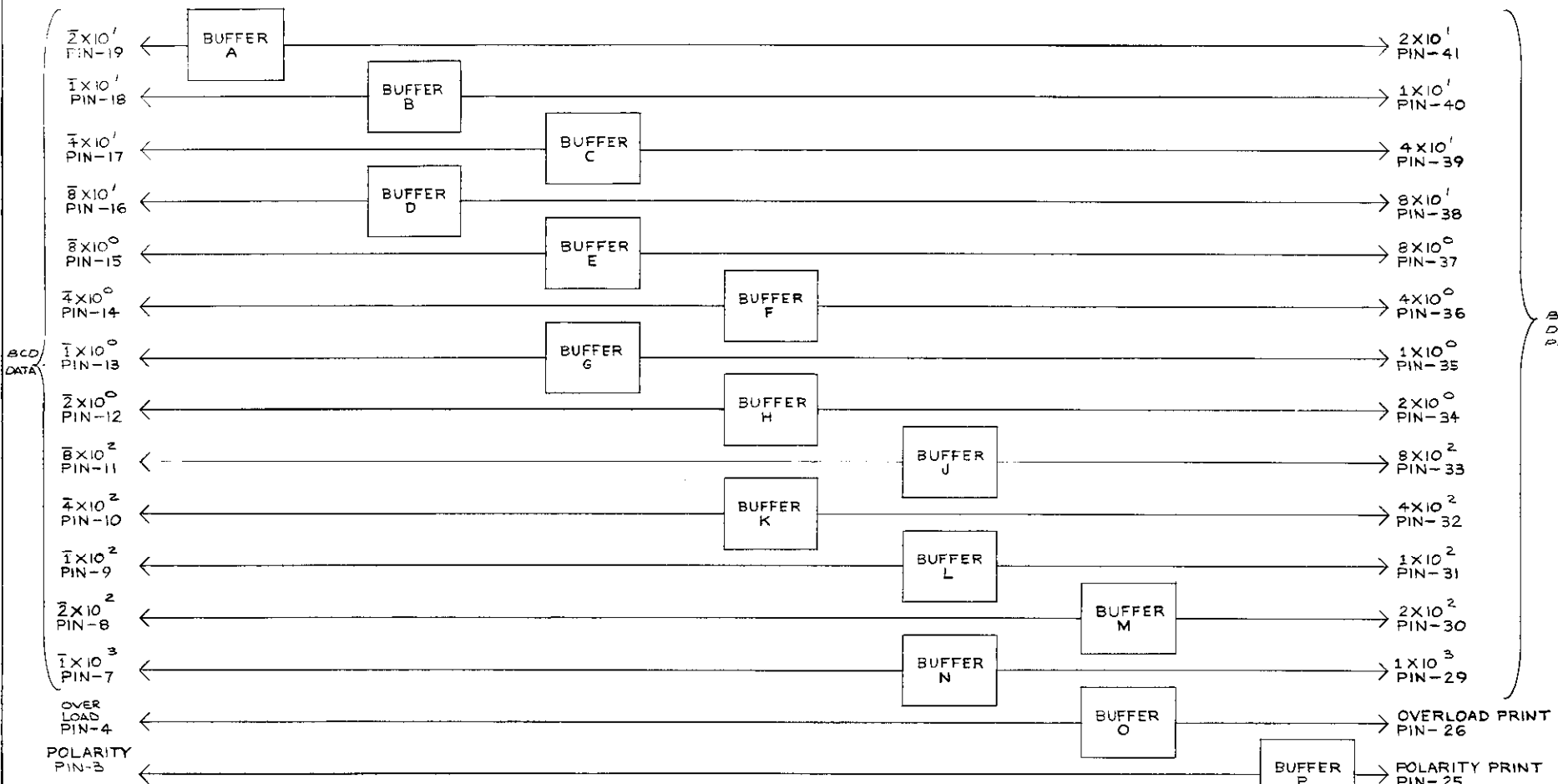

BCD DATA

BCD DATA PRINT

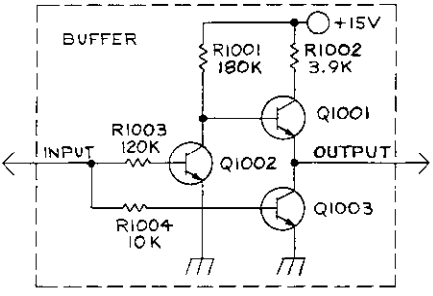

HIGHEST REFERENCE DESIGNATION

R1004A	R1004B	R1004C	R1004D
R1004E	R1004F	R1004G	R1004H
R1004J	R1004K	R1004L	R1004M
R1004N	R1004O	R1004P	Q1003A
Q1003B	Q1003C	Q1003D	Q1003E
Q1003F	Q1003G	Q1003H	Q1003J
Q1003K	Q1003L	Q1003M	Q1003N
Q1003O	Q1003P		

REFERENCE DESIGNATION NOT USED

R1001I	R1002I	R1003I	R1004I
Q1001I	Q1002I	Q1003I	

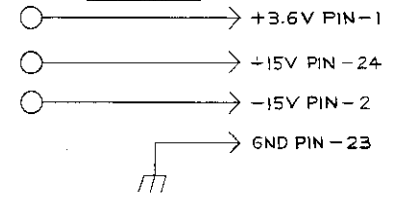

DIMENSIONAL TOLERANCES	UNLESS OTHERWISE SPECIFIED	DATE: 1/22/68	BY: RJC
FRACTIONAL DECIMALS		DATE: 3/17/68	BY: DJV
ANGLES		DATE: 3/17/68	BY: DJV
UNLESS OTHERWISE SPECIFIED		DATE: 3/17/68	BY: DJV
RELEASE		DATE: 3/17/68	BY: DJV

K EITHLEY INSTRUMENTS CLEVELAND OHIO

TITLE SCHEMATIC, PC-218 OUTPUT BUFFER BOARD

PART NUMBER 23457D

REVISIONS			
REV	DESCRIPTION	DATE	BY
1			

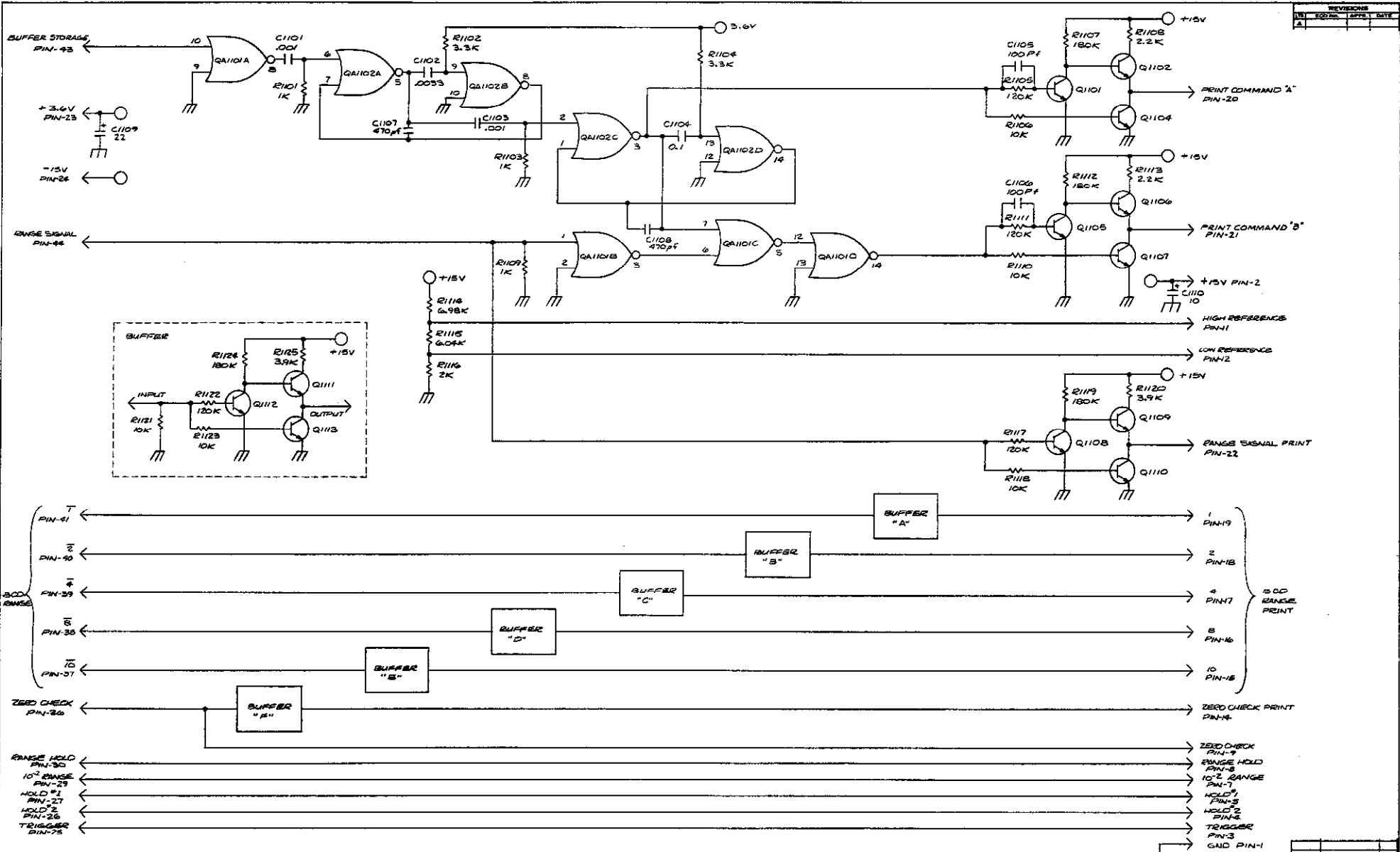

NOTES:
 1. ALL RESISTANCE & CAPACITANCE SHALL BE DESIGNATION IN OHMS & MICROFARADS UNLESS OTHERWISE NOTED.
 2. K = 1000 OHM
 3. pf = PICOFARAD

HIGHEST REFERENCE DESIGNATIONS					
Q112A	Q112B	Q112C	Q112D	Q112E	Q112F
Q113A	Q113B	Q113C	Q113D	Q113E	Q113F
C110	Q110D				

REFERENCES DESIGNATIONS NOT USED	

DIMENSIONAL TOLERANCES UNLESS OTHERWISE SPECIFIED		DRAWING DATE/REV	
FRAC.	DEC.	ANG.	DATE 12/17/67
±.154	±.008	±.1°	DATE 5/17/67
DO NOT SCALE		DATE	

 KEITHLEY INSTRUMENTS CLEVELAND, OHIO	TITLE SCHEMATIC, PC-209 OUTPUT BUFFER BOARD	PART NUMBER 23481E
	MATERIAL FINISH	

PC	DESIGNATIONS
1	1A1 NOT DATA PRINT
2	2A2 NOT DATA PRINT
3	3A3 NOT DATA PRINT
4	4A4 NOT DATA PRINT
5	5A5 NOT DATA PRINT
6	6A6 NOT DATA PRINT
7	7A7 NOT DATA PRINT
8	8A8 GND
9	9A9 RANGE PRINT
10	10A10 RANGE PRINT
11	11A11 NOT WIRED
12	12A12 GND
13	13A13 POLAR TV PRINT
14	14A14 +15V
15	15A15 NOT WIRED
16	16A16 NOT WIRED
17	17A17 +15V
18	18A18 +3.5V
19	19A19 REMOTE ZERO CHECK
20	20A20 REMOTE ID RANGE
21	21A21 REMOTE RANGE WIND
22	22A22 NOT WIRED
23	23A23 PRINT COMMAND A
24	24A24 HIGH RESERVEANCE
25	25A25 LOW RESERVEANCE
26	26A26 NOT DATA PRINT
27	27A27 NOT DATA PRINT
28	28A28 NOT DATA PRINT
29	29A29 NOT DATA PRINT
30	30A30 NOT DATA PRINT
31	31A31 NOT DATA PRINT
32	32A32 GND
33	33A33 OVERLOAD PRINT
34	34A34 RANGE PRINT
35	35A35 GND
36	36A36 GND
37	37A37 GND
38	38A38 GND
39	39A39 GND
40	40A40 NOT WIRED
41	41A41 NOT WIRED
42	42A42 +15V
43	43A43 GND
44	44A44 HOLD * 1
45	45A45 HOLD * 2
46	46A46 TRIGGER
47	47A47 NOT WIRED
48	48A48 PRINT COMMAND B
49	49A49 RANGE SIGNAL PRINT
50	50A50 NOT WIRED

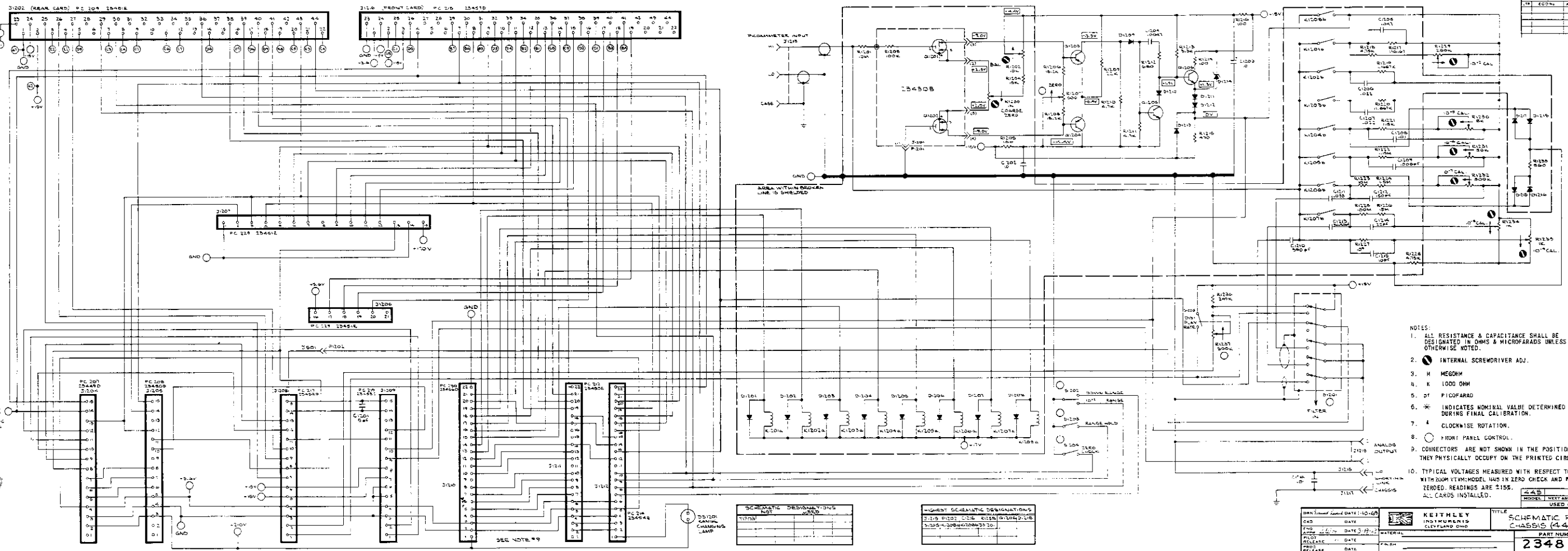

- NOTES:
1. ALL RESISTANCE & CAPACITANCE SHALL BE DESIGNATED IN OHMS & MICROFARADS UNLESS OTHERWISE NOTED.
 2. INTERNAL SCREWDRIVER ADJ.
 3. M MEGOHM
 4. K 1000 OHM
 5. PF PICO FARAD
 6. * INDICATES NOMINAL VALUE DETERMINED DURING FINAL CALIBRATION.
 7. CLOCKWISE ROTATION.
 8. FRONT PANEL CONTROL.
 9. CONNECTORS ARE NOT SHOWN IN THE POSITION OR ORDER THEY PHYSICALLY OCCUPY ON THE PRINTED CIRCUIT BOARD.
 10. TYPICAL VOLTAGES MEASURED WITH RESPECT TO GROUND WITH ZOOM VIEW MODEL HAS IN ZERO CHECK AND PROPERLY ZEROED. READINGS ARE 2155. ALL CARDS INSTALLED.

REVISIONS			
REV.	ECN	APP.	DATE

OUTSIDE VIEW OF 3124

SCHEMATIC DESIGNATIONS	USED
3101	

HIGHEST SCHEMATIC DESIGNATIONS
3113 3120 3126 3138 3140 3142 3143 3144 3145 3146 3147 3148 3149 3150

DATE: 10-10-68	KEITHLEY	TITLE: SCHEMATIC PC-771
DESIGNER: []	INDUSTRIAL	CLASSIS (445)
DATE: 3-11-72	CLEVELAND OHIO	PART NUMBER: 23488E
RELEASE: []	INTERNAL	MODEL: NEXT ASSEMBLY USED ON

REPAIR AND CALIBRATION FORM

For repair or calibration, please fill out this form and return it with your instrument to:
 Sales Service Department
 Keithley Instruments, Inc.
 28775 Aurora Road
 Cleveland, Ohio 44139

R-
 Do not write in this space.

User's Name _____ Telephone _____ Ext. _____
 Company _____ Address _____
 Division _____ City _____ State _____ Zip _____
 Date _____ Model No. _____ Serial No. _____

1. Reason for Return
 Repair and Recalibration
 Recalibration only (No report, except as specified in item 4 on reverse)*
 *If repairs are necessary to meet specifications, they will be in addition to the calibration.
2. Calibration Report Desired
 Report of Calibration Certified Traceable to N.B.S.
 Calibration Report
 Certificate of Compliance
 None
 (for details, see reverse side of this form)

3. To help repair the instrument, briefly describe the problem: _____

4. Is the problem Constant Intermittant
 Under what conditions does the problem occur:
- a) Control setting _____

- b) Approx. Temperature _____ °F
- c) Approx. Temperature variation ± _____ °F
- d) Approx. Humidity (high, medium, low) _____
- e) Line voltage _____
- f) Other (such as line transients, line variations, etc.) _____

5. Please draw a block diagram of the system using the Keithley. List any other pertinent data which can help in the repair. Include charts or other data if available.

Signal Source _____
 Source Impedance _____
 Readout Device:
 Recorder
 Oscilloscope
 Other
 None
 Lengths & Types of Connecting Cables _____

6. What repairs or modifications have been made on this instrument which are not on file with the Keithley Repair Department? _____

7. Please enclose any other pertinent data and charts which you feel might help the Repair and Calibration Department

 Signature Title

CALIBRATIONS AVAILABLE AT KEITHLEY INSTRUMENTS.

Listed and defined below are the four types of calibrations and their associated report formats which are presently available at Keithley Instruments. They fall into the following categories:

1. Report of Calibration Certified Traceable to the National Bureau of Standards
2. Calibration Report
3. Certificate of Compliance
4. Recalibration

All calibration and certification performed by Keithley Instruments is in accord with MIL-C-45662A.

Prices shown below are in addition to repair charges for any work necessary to place a customer's unit into first class condition prior to the calibration.

1. Report of Calibration Certified Traceable to the National Bureau of Standards.

This is a completely documented report, including all basic errors or deviations from nominal settings on appropriate ranges, terminals, dials, etc. Work is performed using the primary standards of the company with secondary transfers kept to a minimum. The NBS test numbers for the latest recalibration of the primary standards are furnished.

By definition, the above is performed in our Standards Laboratory so that random operator induced error is minimized and maximum protection to the equipment used is maintained.

This type of calibration is not recommended for instruments with a basic inaccuracy of 1% or greater. The precision involved in this report makes it uneconomical for such instruments. The Calibration Report listed below (No. 2) would be better suited in this case.

As of 12/1/67 the Report of Calibration Certified Traceable to the National Bureau of Standards is available on the following instruments at the prices listed:

Model 140	\$.325	Model 5155 (Complete Set) . .	\$265
Model 260	\$.220	Model 5155-10 ⁸	\$ 45
Model 261	\$.280	Model 5155-10 ⁹	\$ 45
Model 515	\$.520	Model 5155-10 ¹⁰	\$ 45
Model 630	\$.250	Model 5155-10 ¹¹	\$ 55
Model 660A	\$.200	Model 5155-10 ¹²	\$ 55
Model 662	\$.250	Model 5155-10 ¹³	\$ 75

2. Calibration Report.

This report shows only the cardinal range, terminal, dial, etc. errors as determined by production calibration equipment and personnel. The production equipment is maintained traceable by transfer techniques against the primary standards maintained by the company. We attest to this fact and list basic deviations from nominal but the conditions of calibration are not as precisely controlled as the previous report nor are NBS test numbers supplied.

This report is available for any instrument in our line. As of December 1, 1967, only the following price has been established for this report:

Model 261 \$50

Prices for other units can be estimated upon request.

3. Certificate of Compliance.

This is merely a restatement of the basic guarantee that the instrument was calibrated on equipment that is maintained by our standards personnel against primary standards. No report is issued.

This Certificate of Compliance is available at no charge for any instrument with the exception of the Model 261.

A newly purchased Model 261 or one returned for repair or recalibration is automatically supplied with a Calibration Report (as described in (2) above). The nature of this instrument makes it necessary to complete this report to ascertain specified accuracy. This Calibration Report is forwarded to the customer with the instrument. The \$50 charge is incorporated as part of the normal calibration charge of the Model 261.

4. Recalibration.

This is a recalibration of the instrument according to our factory calibration procedures. The prices for this as of December 1, 1967 are as follows:

Model 260	\$75	(No report supplied. A Certificate of Compliance can be had at no charge if requested).
Model 261	\$50	(Calibration Report as described in (2) above is supplied. See (3) for explanation).

All other instruments are on a time and material basis for the particular unit involved.